



iComfort[®] S30 (12U67) Installation and Setup Guide

**Color Touchscreen Programmable Wi-Fi
Communicating Thermostat**

TABLE OF CONTENTS

Shipping and Packing List	2
General	2
Installing Control System Components	3
<i>Mag-Mount Installation</i>	3
<i>HD Display Installation</i>	4
<i>Smart Hub Installation</i>	4
Wiring for Control System Components	5
Configuring Heat Sections on Air Handler Control	10
Smart Hub Operations	11
<i>Smart Hub Indicators and Connectors</i>	12
<i>Connecting Mobile Application to Smart Hub</i>	13
Installer System Setup	14
Dealer Control Center	16
Equipment - System	17
<i>Equipment - System</i>	17
<i>Equipment - Heat Pump</i>	22
<i>Equipment - Air Conditioner</i>	24
<i>Equipment - Air Handler</i>	24
<i>Equipment - Furnace</i>	25
<i>Equipment - Thermostat (HD Display)</i>	26
<i>Equipment - Zoning Control</i>	27
<i>Equipment - Add / Remove Equipment</i>	27
<i>Equipment - Reset All Equipment</i>	27
<i>Notifications</i>	28
<i>Maintenance History</i>	49
<i>Tests</i>	49
<i>Diagnostics</i>	49
<i>Information</i>	49
System Configurations	50
Glossary	59
FCC Compliance	60
Replacement Parts	60
Index	61

SHIPPING AND PACKING LIST

- 1 - iComfort® S30 which includes:
 - > High definition (HD) wall mounted display interface with a Mag-Mount wall base and optional use wall plate
 - > Smart Hub controller
- 4 - Mounting screws
- 4 - Wall anchors
- 1 - Installation and Setup and User Guides
- 1 - Warranty certificate

GENERAL

This iComfort® S30 is an electronic communicating, color display touchscreen and 7-day programmable interface which communicates directly with a Smart Hub. The Smart Hub controller stores system parameters and settings in non-volatile memory (i.e., retains data when electrical power fails or is turned off). After online registration is completed, the system may then be accessed by the homeowner from anywhere using a remote Internet connection via computer or personal communicating device. This home environmental control system also supports:

- Wireless bands 802.11b, 802.11g and 802.11n,
- Lennox wireless point-to-point connection to other Lennox Smart Hubs in home and other mobile devices running Lennox applications.
- Three languages are supported (English, Français and Español),
- Air conditioning or heat pump units with up to four stages of heat / two stages of compressor operation (2 stages of heat pump heating, 2 stages of auxiliary back-up heating, 2 stages of emergency heating),
- Variable - capacity / multiple - stage heat/cool, universal compatibility (gas/electric/heat pump/air conditioner)
- Dual-fuel capable (iComfort® heat pump only) with two balance points.
- Indoor air quality with time-based notification of consumables including media filters, UVC bulbs, humidifier pads, and PureAir™ system catalyst service / replacement,
- iHarmony® zoning system (2 - 4 zones),
- Lennox iComfort® Equipment Interface Module (Catalog number 10T50) (connects the iComfort® S30 to non-communicating indoor and outdoor units.
- Humidification measurement and control,
- Dew point adjustment control,
- Humiditrol® Enhanced Dehumidification Accessory (EDA),
- Equipment maintenance reminders,
- Heat/Cool mode -- Permits control of heating, cooling, humidification, and dehumidification without user involvement,
- All Lennox branded iComfort® outdoor units have a outdoor temperature sensor factory installed,
- Enhance defrost control options for Lennox communicating heat pumps using Intellifrost™ Adaptive Defrost Control, part number 103369-04 or later.

WARNING

Improper installation, adjustment, alteration, service or maintenance can cause property damage, personal injury or loss of life. Installation and service must be performed by a qualified installer, service agency or the gas supplier

INSTALLING CONTROL SYSTEM COMPONENTS

Before beginning installation, note the type of equipment, number of stages, and any accessories being installed.

DO

- Read this entire document, noting which instructions pertain to your equipment and system requirements.
- Make sure that all wiring conforms to local and national building and electrical codes and ordinances.
- Use thermostat wire pair between the iComfort® and the optional outdoor temperature sensor (may be separate wire pair or two wires of a multi-wire cable).
- Install the Smart Hub near the indoor unit using field-provided fasteners.
- Install the Smart hub on a flat surface away from indoor unit to minimize vibration. Securing Smart Hub to a wall stud is desirable.

DO NOT

- Install on voltages higher than 30VAC.
- Short (jumper) across terminals on the gas valve or at the system controls to test installation. This will damage the iComfort® S30 and void the warranty.
- Install HD display on outside walls or in direct sunlight

- Install Smart Hub to indoor unit or equipment that could induce unit vibration to the unit.
- exceed 300 feet (91m) run when using 18 GAUGE thermostat wire or larger
- allow load from any thermostat connection to be more than 1 AMP.

MAG-MOUNT INSTALLATION

1. Unpacked the HD Display and mag-mount (wall base)
2. Remove Mag-Mount access cover to allow installation to an interior wall that is not in direct sunlight or ventilation.

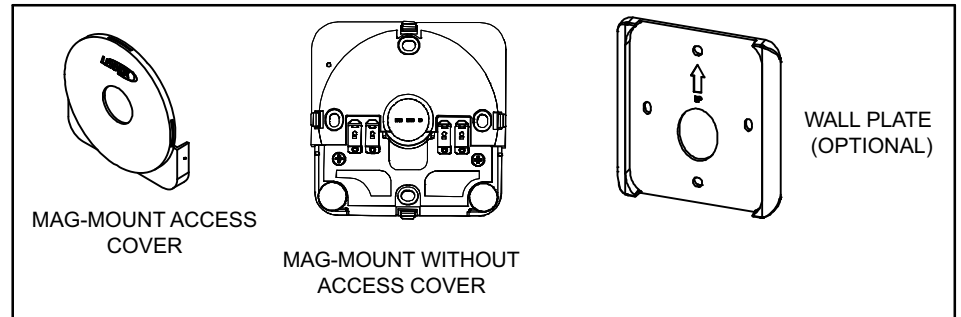

3. Install Mag-Mount in desired location away from direct sunlight or any discharge vents.

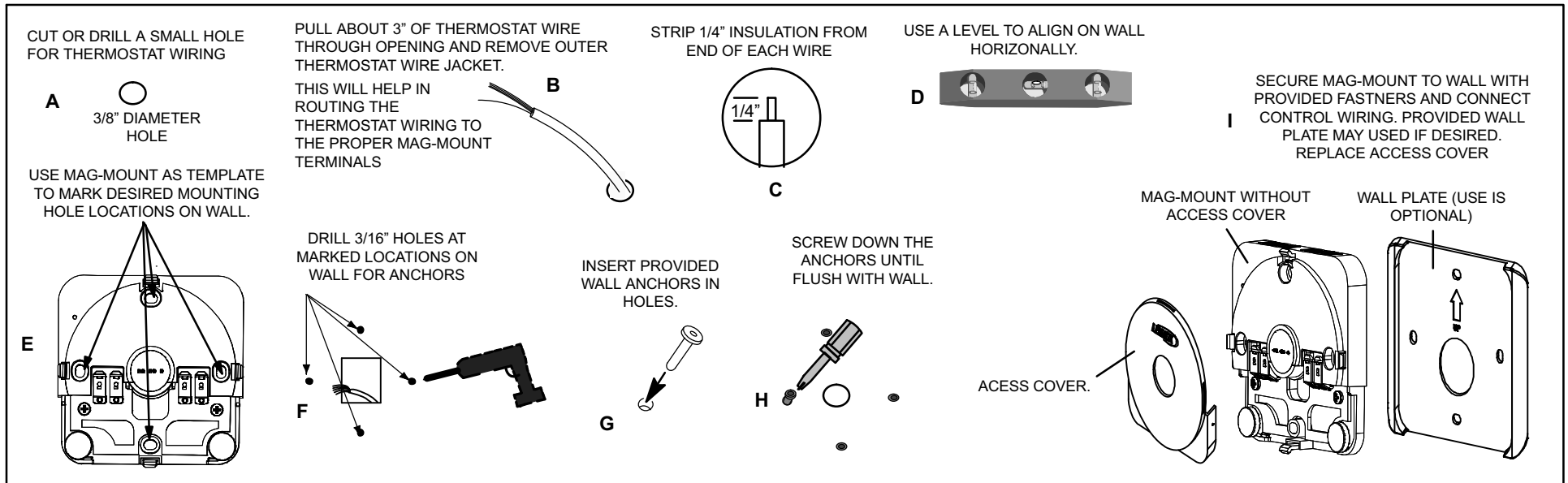
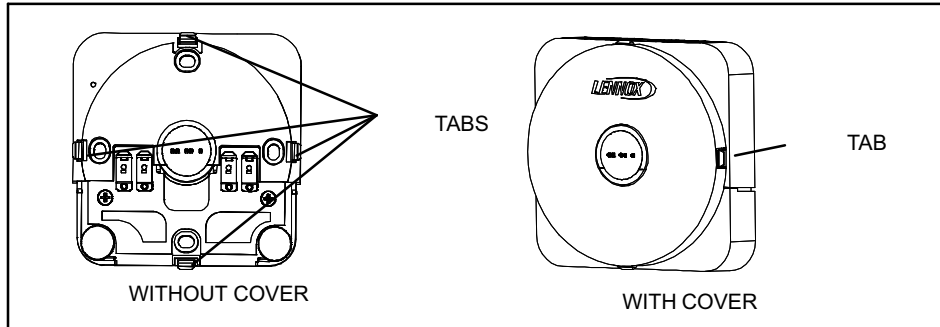

Figure 1. Mag-Mount Installation

HD DISPLAY INSTALLATION

1. Line up HD display with MAG-MOUNT base.
2. Insert bottom of the HD display at 30 degree angle into tabs at bottom of the MAG-MOUNT wall base.



3. Rotate the HD display upward until it snaps into place by pressing on sides.
4. To remove HD display from MAG-MOUNT base simply rotate in either direction the HD display 30 degrees and pull off. **Failure to rotate display before pulling off requires much more force to be used and may pull out wall anchors.**

NOTE: If the HD display is removed from the MAG-MOUNT base, the HD display will shut down and not be able to communicate with the system. System can be control from mobile devices or dealer web portal if registration has been completed.

SMART HUB INSTALLATION

1. Use the following procedure to install the Smart Hub controller. Refer to figures 3 through 11 for making control wiring connections.
2. Mount the Smart Hub near the indoor unit using field-provided fasteners.

3. Unfold both antennas to the vertical position. Adjustments may be required to optimized transmitting and receiving.

NOTE - DO NOT mount the Smart Hub to indoor unit, duct work or equipment that could induce vibration to the module. Mount Smart Hub on flat surface away from indoor unit to minimize vibration. Securing module to a wall stud is desirable. If mounted on metal surface other than above, antennas need to be perpendicular to the metal surface.

⚠ CAUTION

Magnetic Field - Magnets located in this product have far-reaching, strong magnetic fields. They could damage TVs and laptops, computer hard drives, credit and ATM cards, data storage media, mechanical watches hearing aids and speakers.

Keep HD Display away from devices and objects that could be damage by strong magnetic fields.

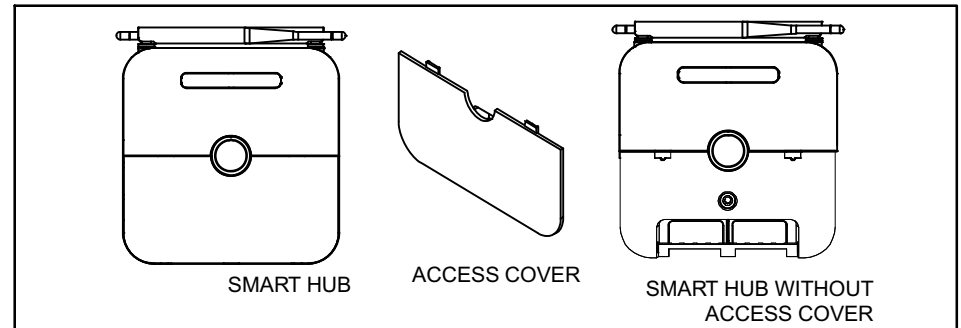

USE SMART HUB AS TEMPLATE TO MARK DESIRED MOUNTING LOCATIONS ON WALL OR STUD.
CAUTION; DO NOT OVERTIGHTEN LOWER MOUNTING SCREW, MAY DAMAGE SMART HUB.

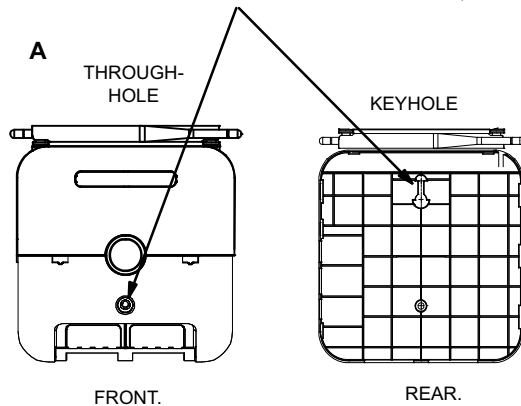

- B** STRIP 1/4" INSULATION FROM END OF EACH CONTROL WIRE

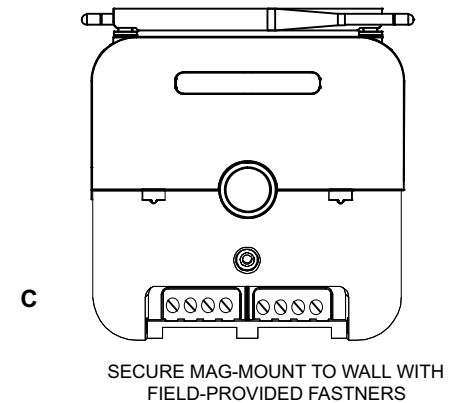
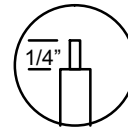

Figure 2. Smart Hub Controller Installation

WIRING FOR CONTROL SYSTEM COMPONENTS

The figure below illustrates the basic Lennox communication control wiring to all system components.

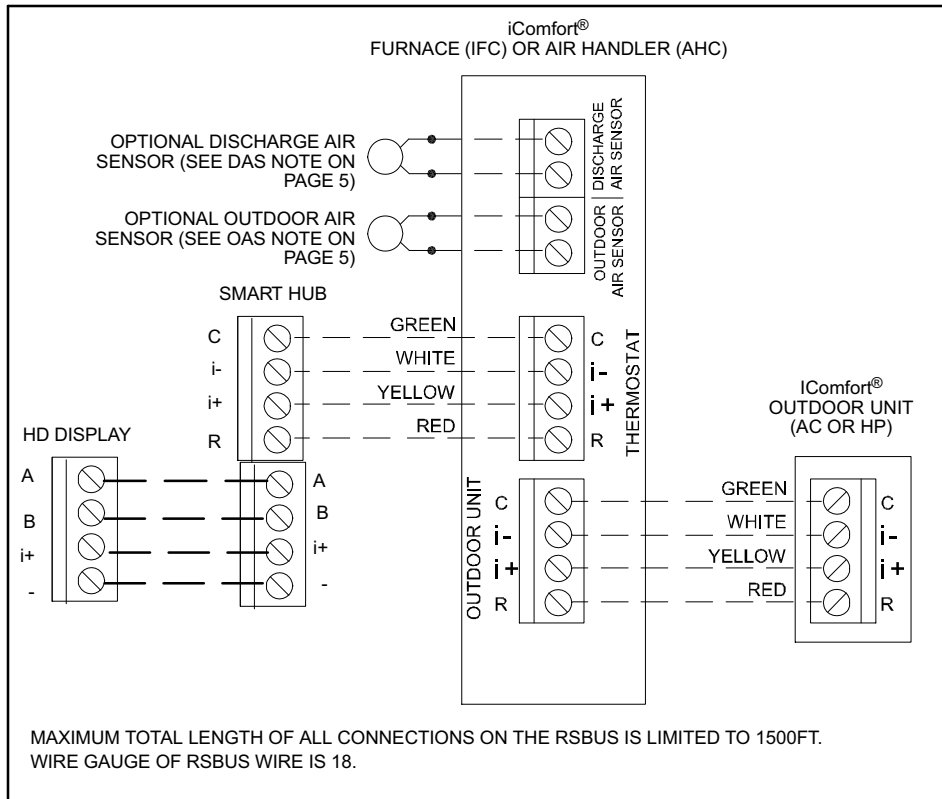

Figure 3. iComfort® Communicating System Wiring 1

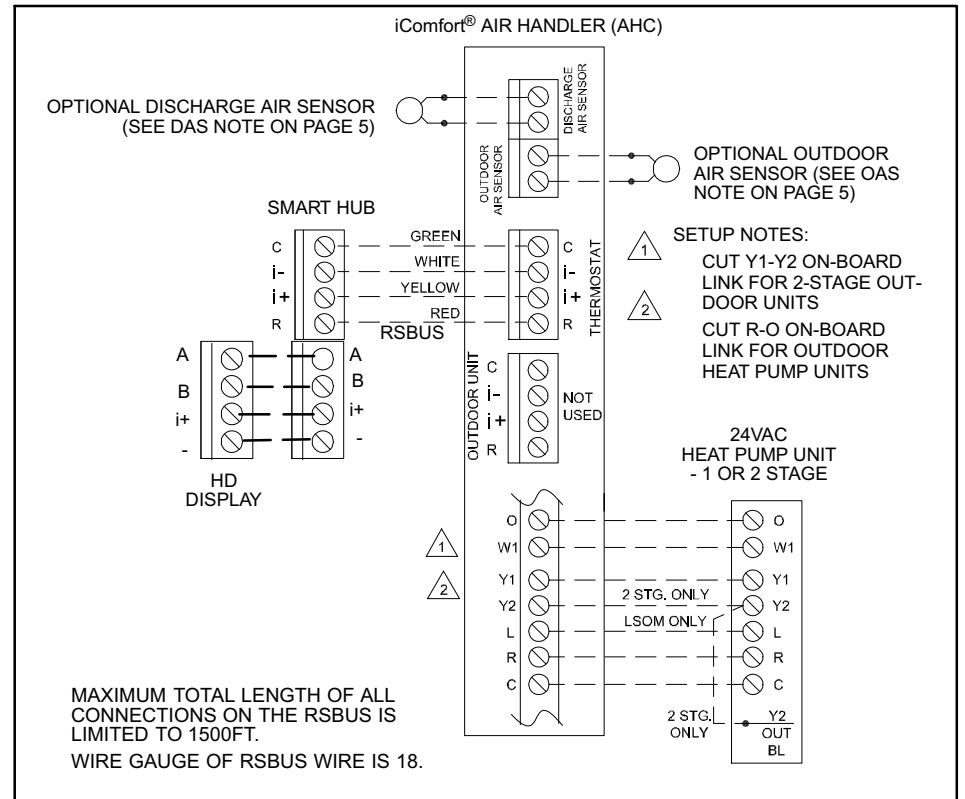

Figure 4. iComfort® Communicating Indoor/Non-Communicating Outdoor (HP) System Wiring

DAS NOTE: The discharge air sensor is intended to be mounted downstream of the heat exchanger and air conditioning coil. It must be placed in free airflow, where other accessories (such as humidifiers, UV lights, etc.) will not interfere with its accuracy. Wiring distance between the IFC or AHC and the discharge air sensor should not exceed 10 feet when wired with 18-gauge thermostat wire. 2

OAS NOTE: The optional outdoor temperature sensor wiring distance between the IFC or AHC should not exceed 200 feet when wired with 18-gauge thermostat wire.

RSBUS NOTE Maximum total length of all connections on the RSBUS is limited to 1500 ft. (450 m). Maximum length between components is 300 ft. (90 m).

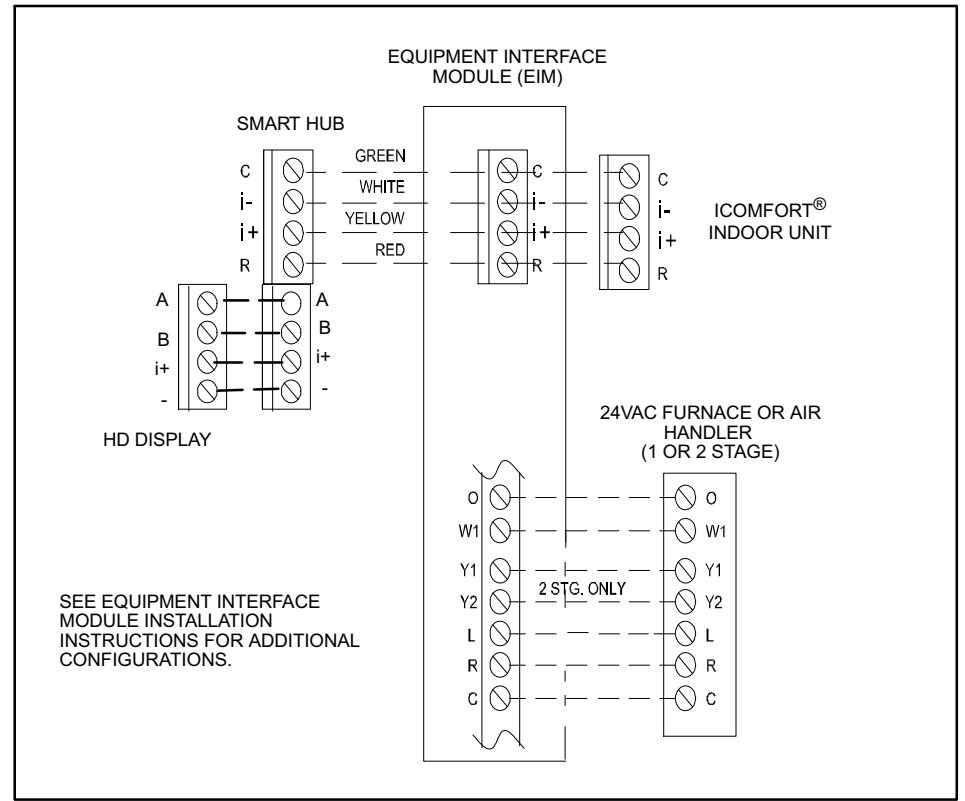
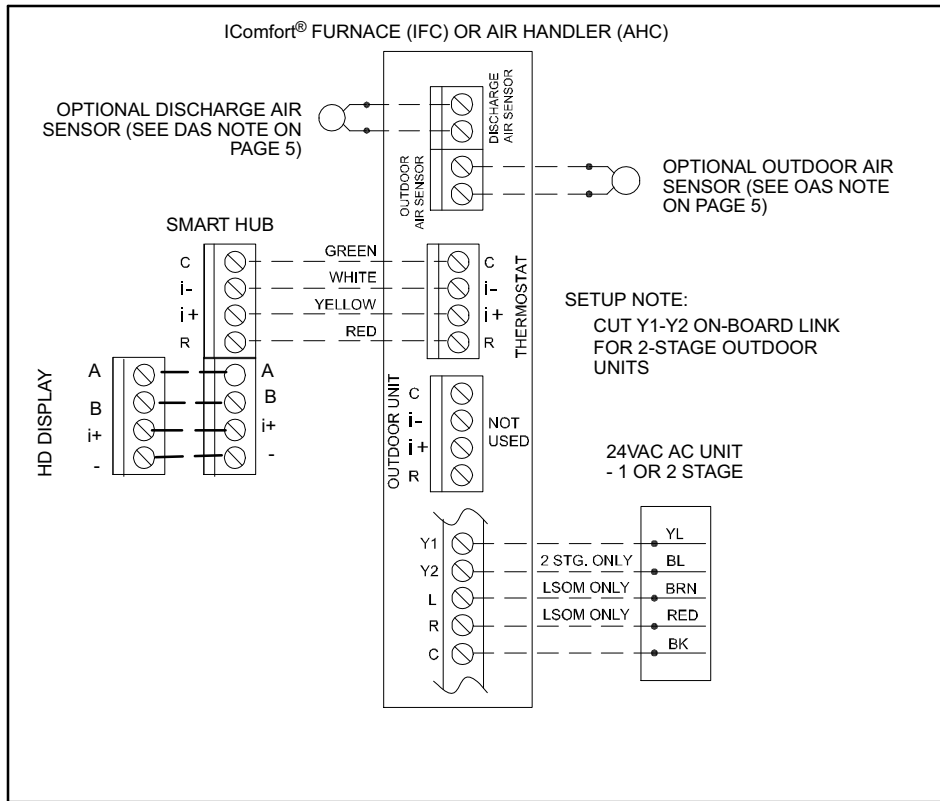

Figure 5. iComfort® Communicating Indoor/Non-Communicating (AC) Outdoor System Wiring

Figure 6. iComfort 30® Control System, Equipment Interface Module, Non-communicating (Conventional) Indoor Unit and iComfort® Outdoor Unit.

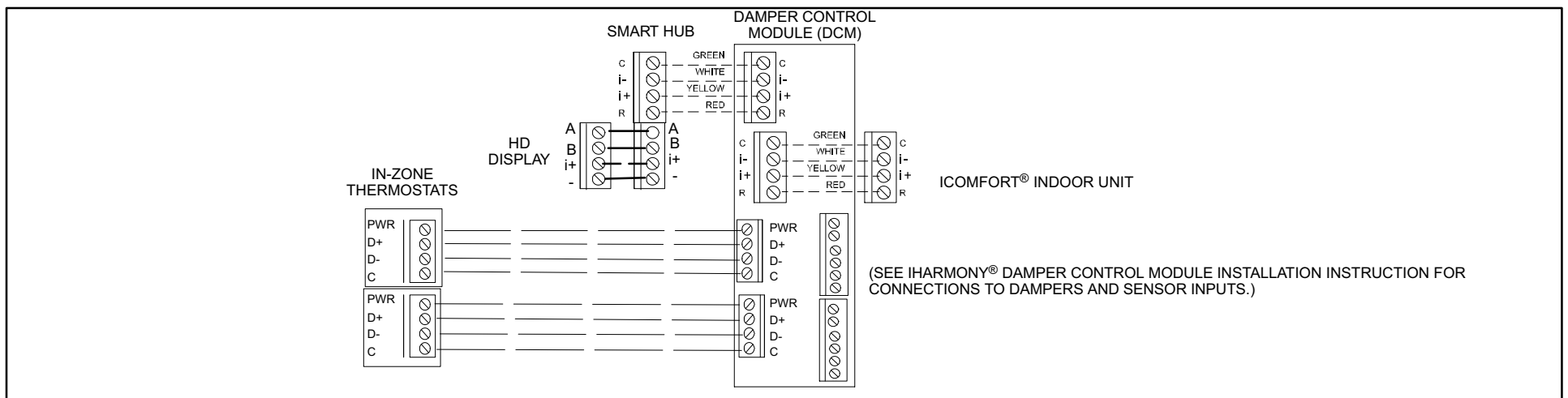
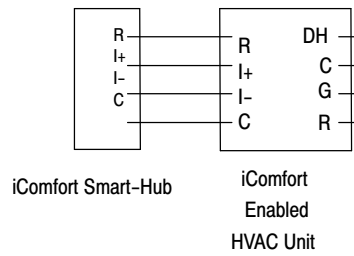
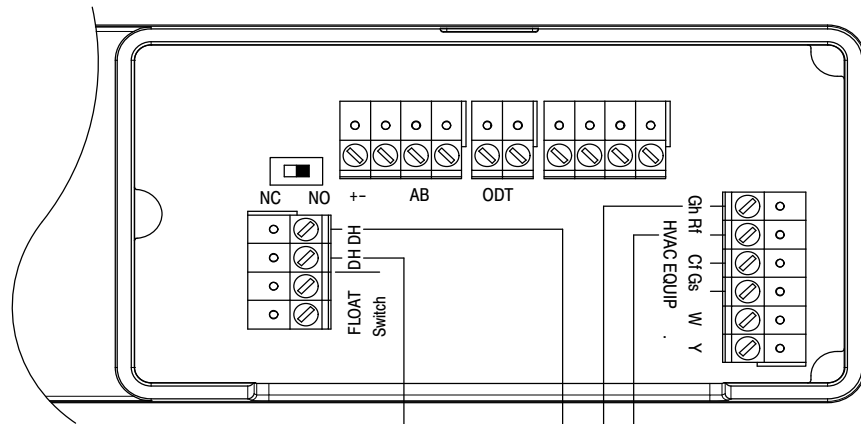

Figure 7. iComfort Wi-Fi®, iHarmony® Damper Control Module, and Communicating Indoor Unit

AUXILIARY DEHUMIDIFIER MODELS HCWHD3-070 AND HCWHD-095



AUXILIARY DEHUMIDIFIER MODELS HCWHD-090 AND HCWHD-135

NOTE: HCWHD-065 IS NOT COMPATIBLE

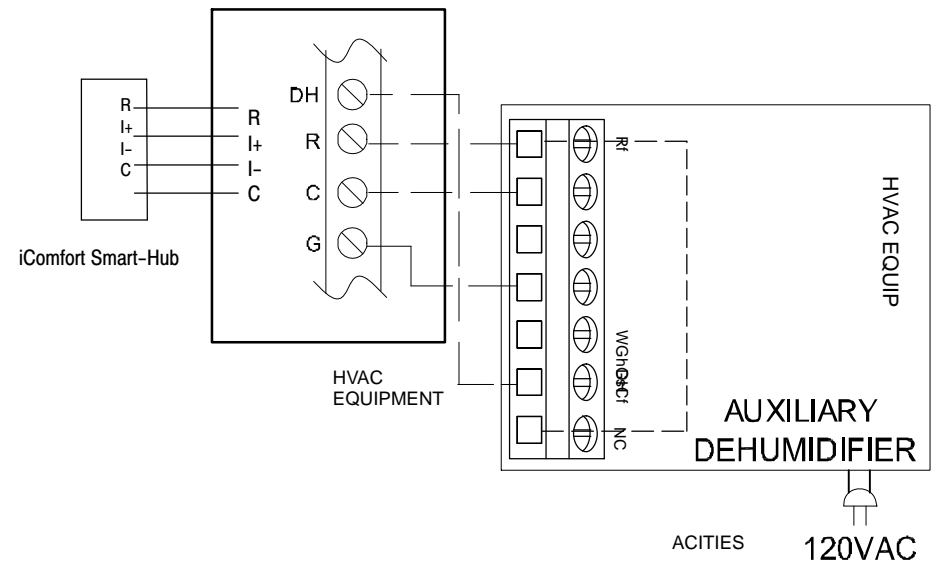

Figure 8. Optional Accessories Wiring (Dehumidifiers)

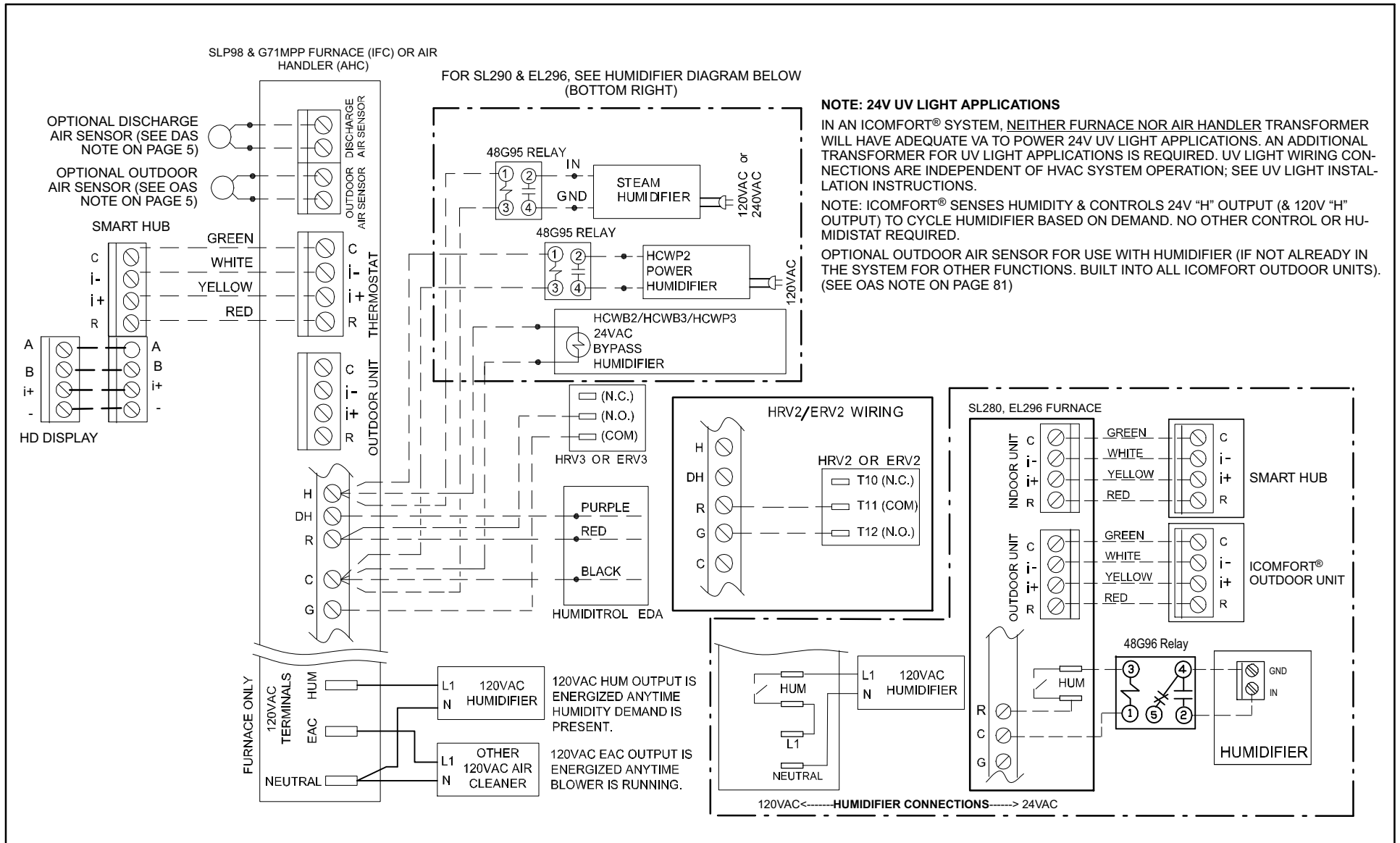

Figure 9. Optional Accessories Wiring (Humidifiers)

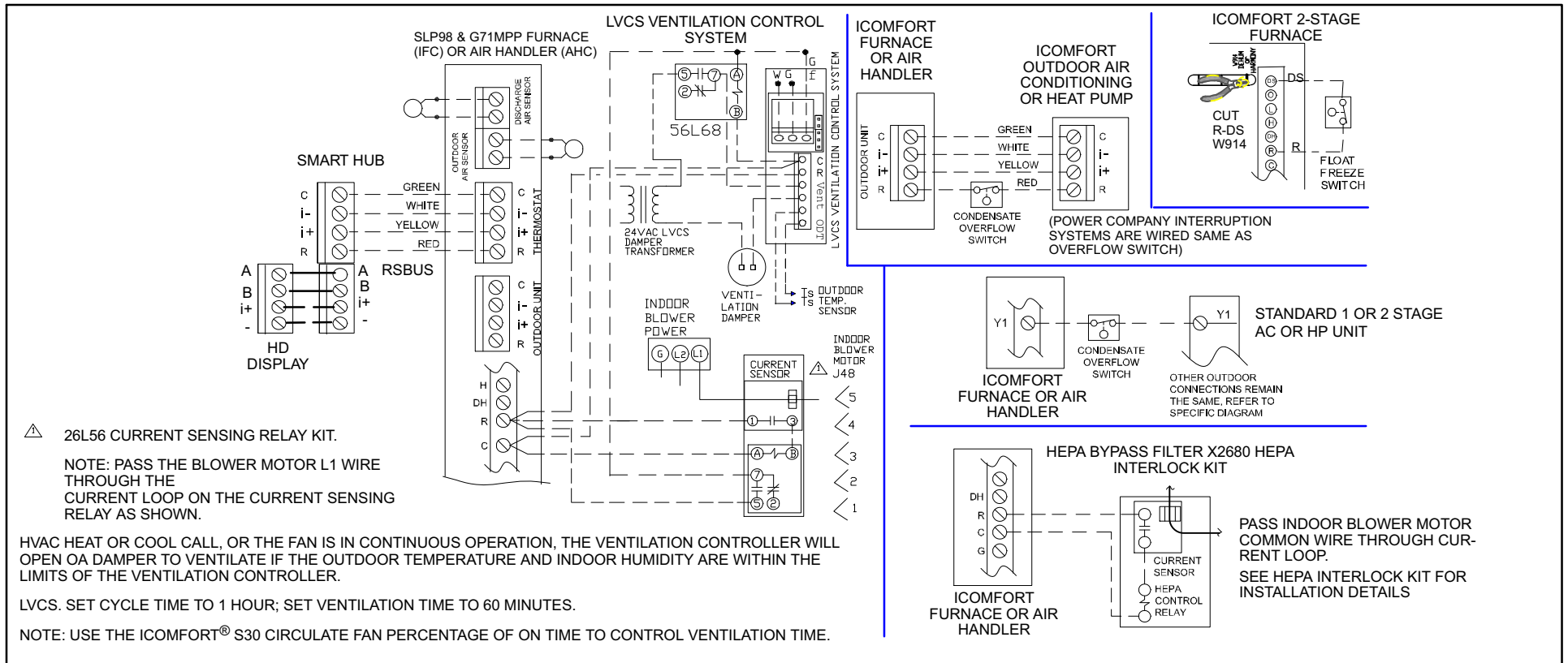

Figure 10. Optional Accessories Wiring

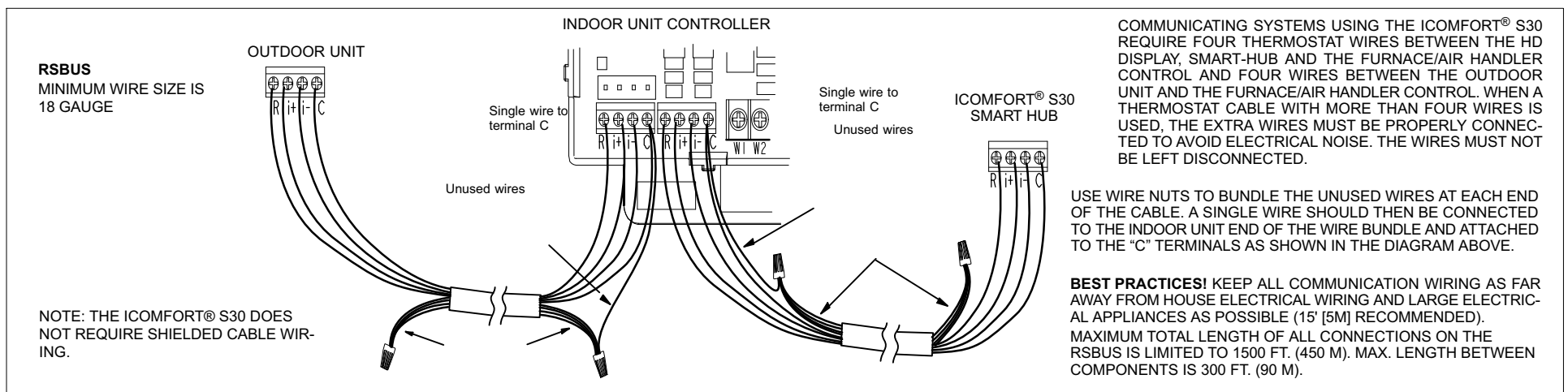

Figure 11. Thermostat Wire Termination in Communicating System

CONFIGURATING HEAT SECTIONS ON AIR HANDLER CONTROL

IMPORTANT: PRIOR TO RUNNING THE ICOMFORT S30 INSTALLER SETUP, ELECTRIC HEAT MUST BE MANUALLY CONFIGURED!

IMPORTANT: After electric heat strips are installed, the air handler control must be manually configured to detect the number of electric heat sections. (See also 506181-01 for complete configuration guide.)

This procedure is applicable only to the CBX32MV-XX-230-6-06 and higher and CBX40UHV (all models). To configure the heat strips so that they will be detected by the thermostat:

- Power must be applied to the air handler but NOT to the thermostat. Remove thermostat from base plate or remove wires to thermostat at the air handler.
- On the air handler control, unit should be in idle mode (decimal blinks at 1 Hertz—0.5 second ON, 0.5 second OFF).
- Select field test mode—press and hold the push button until solid “-” appears; release button. Display will blink.
- Press the push button and wait for the display LED to show “H” (capital H), then release the button.
- The air handler control cycles the indoor blower motor “on” to the selected heat speed and stages the electric heat relays “on” and “off” to automatically detect the number of electric heat sections. The air handler control stores the number of electric heat sections, then automatically exits “Field Test Mode”.
- At this point, the iComfort® S30 will now detect the heat strip information stored in the air handler control.

Air Handler Control

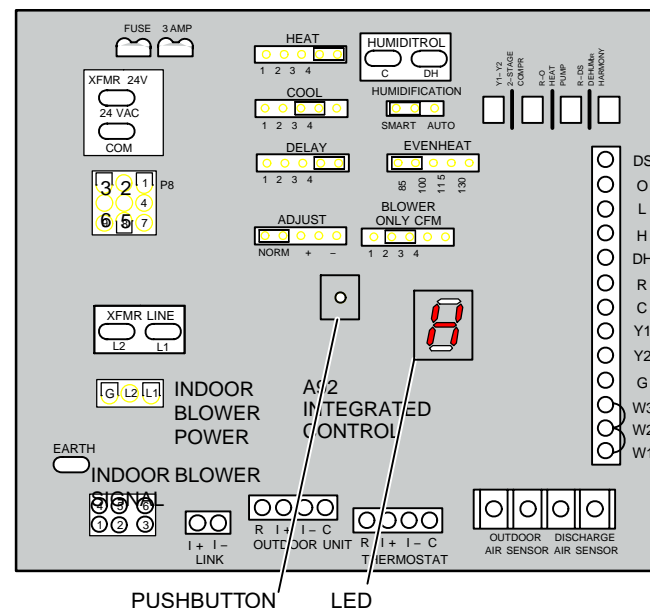

SMART HUB OPERATIONS



Smart Hub Wi-Fi

The Smart Hub internal Wi-Fi module can remain connected to the home Wi-Fi network (and the internet) while establishing and maintaining special ad-hoc Wi-Fi P2P (peer-to-peer) network connections (Smart Hub Wi-Fi network) with nearby mobile devices. These direct connections are independent of the home Wi-Fi network and operate whether the home Wi-Fi network is connected to the Internet or not, or whether the home Wi-Fi network is operating or not.

This special Smart Hub Wi-Fi network can connect a Smart Hub to nearby Wi-Fi-capable mobile devices such as smart phones and tablets that are running the Lennox iComfort® S30 service mobile application.

A service technician in the home can use a smart phone or tablet running the iComfort® S30 service mobile application to connect to a nearby Smart Hub whether or not the Smart Hub is connected to the home Wi-Fi network, the home Wi-Fi network is operating, or the home Wi-Fi router is connected to the Internet. More than one mobile device can connect to the Lennox-managed local network through the Smart Hub Wi-Fi network.

The iComfort® S30 service mobile application running on a mobile device cannot reach a Smart Hub through the Internet or through the home Wi-Fi network. The mobile device must be Wi-Fi-capable, must be located in the home, and must use Smart Hub Wi-Fi to connect to a Smart Hub.

A mobile device connected to a Smart Hub through a Smart Hub Wi-Fi network cannot see or interact with the Internet through the Smart Hub even if the Smart Hub is connected to the Internet through the home Wi-Fi network. The service technician cannot check email or do an Internet search on a mobile device through a Smart Hub Wi-Fi connection.

Lennox-Managed Local Network

Smart Hubs have the ability to connect to other iComfort® S30 devices running Lennox software to create a special Lennox-managed local network. A Lennox-managed local network is independent of the actual physical network it is running on, and can operate over the home Wi-Fi network or over the Smart Hub Wi-Fi network.

A Lennox-managed local network is similar to the home LAN (local area network) that operates over the home Wi-Fi network in that it provides a means for devices to communicate with each other. A Lennox-managed local network is different from the home LAN in that it allows *only* Lennox devices to connect to it. A Lennox-managed local network operates only between:

- A Smart Hub and other Smart Hubs installed in the home, over the home Wi-Fi network
- A Smart Hub and a nearby Wi-Fi-capable mobile device running the iComfort® S30 service mobile application, only over a Smart Hub Wi-Fi network

Up to eight Smart Hubs, each controlling a separate HVAC system in a home, can be connected together over a Lennox-managed local network. And, even if eight Smart Hubs are connected to each other over the Lennox-managed local network running on the home Wi-Fi network, a mobile device running the iComfort® S30 service mobile application can still connect to the Lennox-managed local network over the Smart Hub Wi-Fi network.

Wi-Fi-capable mobile devices running the iComfort® S30 service mobile application must be on the premises and connect directly to a Smart Hub through a Smart Hub Wi-Fi network. The iComfort® S30 service mobile application cannot connect to a Smart Hub through the home Wi-Fi network or from the Internet.

Lennox Center Push Button Switch

The Smart Hub center push button switch:

- Resets the Smart Hub
- Starts the process of creating a special Lennox-managed local network between two iComfort® S30 devices
- Starts the process of adding another iComfort® S30 device to an existing Lennox-managed local network

A iComfort® S30 device can be another Smart Hub installed in the home or a Wi-Fi capable mobile device like a smart phones or a tablet running the iComfort® S30 service maintenance application.

A Lennox-managed local network can connect Smart Hubs together through the home Wi-Fi network or connect a Wi-Fi-enabled mobile device running the iComfort® S30 service maintenance application to a Smart Hub through a Smart Hub Wi-Fi network.

The identity of devices requesting connection to a Smart Hub is rigorously authenticated before connection is allowed to ensure that only iComfort® S30 devices connect to a Smart Hub.

Smart Hub Indicators and Connectors

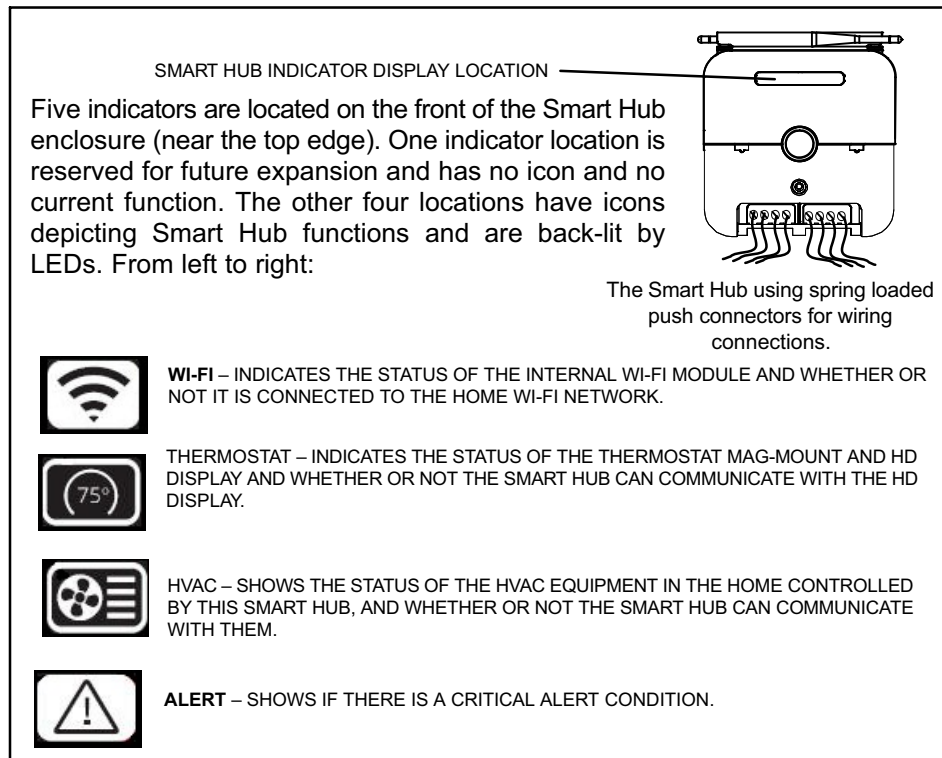

Figure 12. Smart Hub Indicators and Connectors

These LEDs have a red LED chip and a green LED chip in the package and can show red, green, or amber colors, steady or flashing.

As a general rule:

- Unlit indicators show there is no power to the Smart Hub or its software has suffered a critical initialization error.
- Steady amber indicators show Smart Hub boot up and self-check processes are in progress or have completed. Boot up and self checks normally complete rapidly, so amber indicators may appear only briefly (except for the Wi-Fi indicator).
- Flashing amber Wi-Fi indicator shows that the Wi-Fi module check is in progress. Steady amber Wi-Fi indicator shows that the Wi-Fi module has passed its check but is not connected to the home Wi-Fi network.

- Flashing green indicators show acquisition and test of resources across wired interfaces to the Mag-Mount / HD Display and to installed HVAC equipment
- Steady green indicators show that the associated function is connected and operating normally.
- Flashing red indicators show a problem with the associated function.
- Flashing red ALERT indicator shows that a critical alert condition exists. If one of the other indicators is also flashing red, that is the likely source of the alert. If no other indicators are flashing red, the source of the alert is not defined.

CENTER PUSH BUTTON INDICATOR

The center push button has a RGB (red-green-blue) LED backlight that indicates the Lennox-managed local network communication status of the Smart Hub, and if the Smart Hub is transferring a software image from a flash drive plugged into the USB port. While this LED indicator can show any color, it is currently limited to amber, green, or blue.

When the Smart Hub is in a **normal steady state**, -- when the Smart Hub is in normal day-to-day operation -- the center push button backlight shows:

- Steady blue when there is only one Smart Hub in the home and it is not connected to a mobile device running a iComfort® S30 application.
- Steady blue when there is more than one Smart Hub in the home, but this Smart Hub is not connected to any other Smart Hub.
- Steady green when the Smart Hub is connected to another Smart Hub in the home through a Lennox-managed local network.

During various Smart Hub **transient states** -- when the Smart Hub is engaged in a special task that should complete soon -- the center push button backlight shows:

- Steady amber (briefly) while the Smart Hub conducts self tests and boots up.
- Flashing amber while software or firmware updates for an iComfort® S30 system component or a connected field-upgradable HVAC asset is being transferred from files on a flash drive plugged into the Smart Hub USB port.
- Steady blue while the Smart Hub conducts checks on its internal Wi-Fi module and remote HVAC assets. (Icon indicators show progress.)
- Flashing green when the Smart Hub is attempting a Lennox-managed local network connection with another Smart Hub in the home or with a mobile device running the iComfort® S30 service maintenance application.
- Steady green when the Smart Hub is connected to a mobile device running the iComfort® S30 service maintenance application through a Lennox-managed local network connection. (This is considered a transient state because the mobile device will disconnect from the Lennox-managed network when the task at hand is complete.)

MOBILE APPLICATION DIRECT CONNECTION TO ICOMFORT® S30 SMART HUB

CONNECTING MOBILE APP TO ICOMFORT® S30 SMART HUB USING SMART-HUB WI-FI*

1. Press the center Lennox button once on the Smart-Hub. After pressing, center green ring LED starts blinking.
2. Launch Lennox Service Mobile Application if not yet running.
3. Select **DIRECT-xy-ABCD SSID*** and connect to it. (*example)
4. Connect and enter "PIN". The character ABCD in SSID is the PIN.
5. After connecting to the mobile device the center green ring LED stays solid green.
6. Proceed to the *Installer System Setup* section to continue.

RESTARTING SMART HUB

RESETTING SMART HUB - Pressing the center Lennox button for more than 5 seconds will restart the SMART HUB.

ICOMFORT SMART HUB NORMAL CONDITION

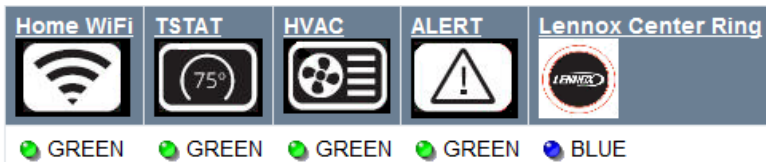

* SMART-HUB WI-FI is a self-contained Wi-Fi network (peer-to-peer) hosted by the SMART-HUB and totally independent of any other local network. SMART-HUB WI-FI is used to connect multiple SMART-HUBs devices and mobile devices running either the Consumer or Dealer Mobile applications. Mobile devices will require the SMART-HUB SSID and PIN number to connect. Both SSID and pin number are located on the SMART-HUB device. If multiple SMART-HUBS are installed, access to only one is required to control the entire system.

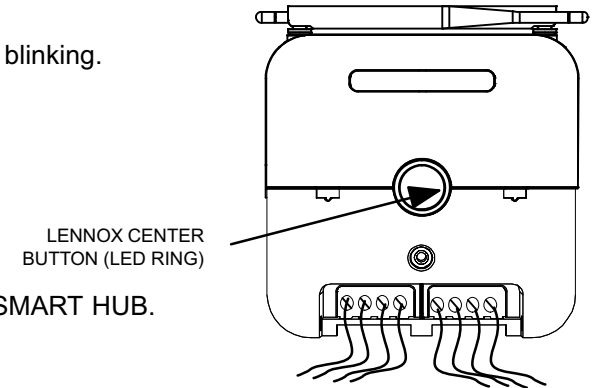

Figure 13. Connecting Mobile Application to iComfort® S30 Smart Hub using Smart Hub Wi-Fi

INSTALLER SYSTEM SETUP



The following procedures are written for the installer setup using the HD wall display.

When power is first applied to the system all communicating devices attached to the system (air handler or furnace, outdoor unit or zoning control) will automatically be configured using optimal factory default settings based on system type, capacity and other configuration considerations.

BOOTUP SCREEN

When power is applied to the system, the HD display or sometimes referred to as thermostat will display a welcome screen. For the dealer mobile application, refer to figure 13 for establishing a wireless connection between the mobile application and Smart Hub

If there is an issue with communication between any component attached to the iComfort® S30, a **critical alert message** will appear on the screen. The alert message will provide detail information concerning the possible cause. Once the issue is corrected and power is restored to the system the first screen in the initial setup sequence will appear.

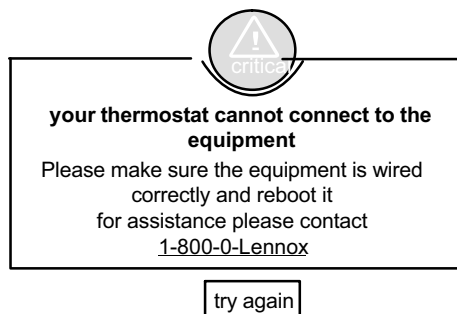

NOTE: If a critical low battery screen is displayed, the system will automatically start charging the HD display internal battery. On the screen the word “charging”

will appear. Once “charging” disappears (typically 3 to 10 minutes) then the display will automatically start-up.

DEALER INFORMATION

The first screen in the installer system setup sequence is the dealer information screen. Here either the dealer ID and/or phone number can be added. When the system is connected to the Internet, the remaining information is automatically populated by the Lennox server. All information can be entered manually if desired however.

NOTE: Not all information for this screen is viewable on a single screen. Use a finger to swipe up to access the remaining information on the screen.

Information Required: Dealer ID and / or dealer phone number. Information that can be manually entered is name, email website, dealer address which includes address 1, address 2, city state and zip code. Once completed press **continue**.

Warning Screen: If either the dealer ID or phone number is NOT provided, a warning screen will appear. The warning screen will provide information on the limitation imposed on the system if this information is not provided. Press **no** to return to the previous screen to complete the information requested or press **yes** to continue.

GENERAL INFORMATION

IMPORTANT: IF THE FOLLOWING INFORMATION IS NOT COMPLETED THE ICOMFORT®S30 WILL NOT BE ASSOCIATED TO THE DEALER IN DAVENET.

On this screen general information needs to be verified or changed. Press any item to change its contents. A pop-up screen will appear that will allow the information to be added or changed.

Information Required:

1. Select desired language (ENGLISH, FRANÇAIS, ESPAÑOL).
2. Select country / region.
3. Select time and date which includes time, date, time zone, daylight savings time (ON/OFF) and temperature unit (Fahrenheit or Celsius).

Once completed press **continue**.

HOME ADDRESS

On this screen the homeowner address needs to be verified or changed. Press any line item to change its contents. Information to be added is address 1, address 2, state, city and zip code.

Complete the requested information and press the continue button.

EQUIPMENT FOUND

This screen will display any communicating equipment the system has detected (air handler, outdoor unit, smart hub and zoning control during initial powering up of the system).

NOTE: When a Lennox Equipment Interface Module (EIM) is used and configured either as a furnace or air handler, then the component would appear as either EIM-Furnace or EIM-Air Handler. When using a EIM the outdoor unit may be either a Lennox communicating or any standard 24VAC non-communicating unit.

NOTE: Not all equipment may be visible from the equipment found system screen. Use a finger to swipe up to access additional information (if applicable) listed at the bottom of the system box.

If non-communicating equipment needs to be added, it can be done so from this screen.

NON-COMMUNICATING EQUIPMENT

When selecting the non-communicating (24VAC) equipment icon a screen will appear listing various equipment that can be added. When selecting a applicable component, a green check will appear next to the item.

NOTE - Also a temporary dialog box will appear indicating: Updating - Wait while we check for dependencies.

NOTE: Selecting an outdoor unit type only appears if a communicating outdoor unit is not detected by the system. Selections are one or two stage heat pumps or air conditioners. Other equipment that can be added are humidifiers and dehumidifiers.

Once completed press **done** which will display the equipment now screen. There the additional non-communicating equipment will now be displayed along with the communicating equipment.

Once completed press **continue**.

REMINDERS

This screen allows you to set reminders as either disabled or 3, 6, 12 or 24 months and also custom by specific date.

Reminders may be set for replace filter 1, replace filter 2, replace UV blub, replace humidifier pad, PureAir maintenance and maintenance reminder. Once a reminder is set for a specific item, press **done** to return to the previous screen.

Once completed press **continue**.

IHARMONY ZONING

This screen will only appear if the iHarmony® zoning system is detected.

This screen allows you to rename each zone using provided preset names or custom name. This screen will not appear if iHarmony component hardware is not detected by the system.

Press on any zone to rename it. A screen will display that list several predefined names that can be used which are master bedroom, guest bedroom, kitchen, living room, media room, dining room library or custom. When a predefine name is selected, a green check-mark will appear next to the selected name.

When creating a custom name, select custom, enter a name and press back to return to the previous screen. A new unique zone name can be created for all four zones.

Once done, press **done** to return to the zoning screen and verify the new name is being used for the specific zone.

Once completed press **continue**.

SET UP AIRFLOW PER ZONE

This screen will allow the installer to setup the airflow per zone. The types of circulation per zone are:

- **Blower Circulation Airflow** (gray) which includes total, assigned, minimum and maximum airflow
- **Heating Circulation Airflow** (red) which includes total, assigned, minimum and maximum airflow
- **Cooling Circulation Airflow** (blue) which includes total, assigned, minimum and maximum airflow.

Press on the circled green arrow to select a specific zone. The zone will explain to allow the installer to adjust CFMs for each circulation airflow type. Use the plus and minus buttons to adjust CFMs up and down.

Once completed press **continue**. The next screen that will appear is the **Dealer Control Center**.

DEALER CONTROL CENTER

This menu provides access to the dealer for performing various functions as listed below:

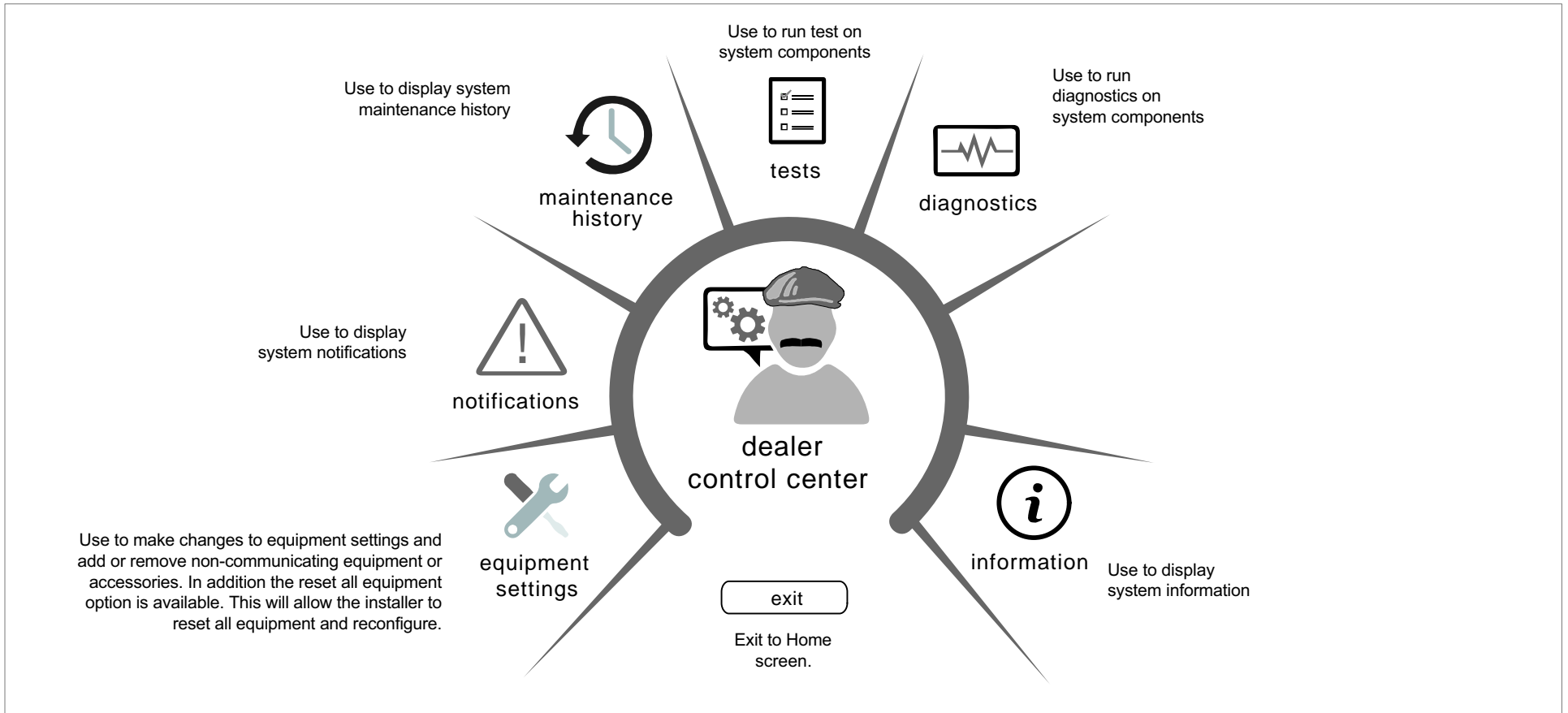



EQUIPMENT

Selections listed in this section are dependent on system hardware configuration. Not all options will be available.

NOTE: When changing the default settings for any parameter, there is a possibility that it will affect the settings for another parameter. If this happens, a pop-up message will be displayed listing the other affected parameters and their new automatically set values.

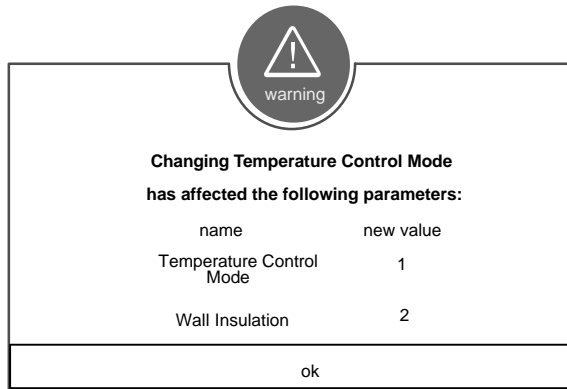

SMART HUB

The following is a complete list of all possible parameters under System. Parameters actually available are dependent on the Lennox communicating equipment type detected and non-communicating equipment added.

ABOUT

This screen provides information concerning language supported, equipment type name, control software revision, model, control mode number, control serial number, control hardware revision, protocol revision number, device product level, 24VAC average power consumption, 24VAC peak power consumption, compatible devices list, application code memory size and micro-controller part number.

EQUIPMENT NAME

A unique name can be assigned to this component. Name can be up to 29 characters. Name can consist of letters, numbers, special characters and spaces.

PUREAIR TIMER SELECTION

The PureAir™ Air Purification System combines multiple air purification technologies into a single, state-of-the-art, air purifier. This selection allows timer to be based on either calendar time or system run-time. Default is calendar time.

SMOOTH SETBACK RECOVERY

When enabled, smooth set back begins recovery up to two hours before the programmed time so that the programmed temperature is reached at the corresponding programmed event time. Assume 12°F per hour for first-stage gas/electric heating and 6°F per hour for first-stage compressor based heating or cooling. With Smooth Set Back disabled, the system will start a recovery at the programmed time. Options are enabled or disabled. Default is enabled.

GAS HEATING ACTIVATION TEMP DIFFERENCE

Range is 0.5 to 10°F. Default is 1.5°F and can be set in increments of 0.5°F. Adjustments are in increments of 0.5°F. When the system is dual-fuel and steady state while operating at full HP demand, this is the amount of °F below the set point that is allowed before allowing to switch to gas heat.

ELECTRIC HEAT CONTROL MODE (XC17, XP17, XC21 AND XP21 ONLY)

In heat pump applications, the electric heat is staged to provide supplemental heat to meet desired comfort levels. When the electric heat section is used in applications that do not have a heat pump, the elements are staged to limit heat so that it meets heating demands only. Options are standard and EvenHeat. Default is EvenHeat.

EVENHEAT DISCHARGE TEMP

When in EvenHeat Control Mode, the iComfort® S30 will stage the electric heat sections to maintain a constant Discharge Air Temperature. The system must have a discharge sensor connected to the system to show this parameter.

NOTE: Not selectable on XC/XP25 applications. Electric heat elements will be staged on by the demand of the iComfort® S30.

Range is 85 to 130°F. Default is 85°F. Adjustments can be made in increments of 15°F.

GAS HEAT CONTROL MODE (SLP98 ONLY)

Options are Staged, Load Tracking Variable Capacity and Variable Capacity. Default is Staged.

Staged

Some furnaces can be configured to provide up to four stages of gas heat operation. When staged heating is chosen, the iComfort® S30 allows you to choose between 1, 2, 3 and 4 stages of heat. Single – stage heat: 1st stage provides 100% of full capacity.

- Two – stage heat: 1st stage provides 70% of full capacity; 2nd stage provides 100% of full capacity.

- Three – stage heat: 1st stage provides 60% of full capacity; 2nd stage provides 80% of full capacity; 3rd stage provides 100% of full capacity.
- Four – stage heat: 1st stage provides 35 or 40% of full capacity; 2nd stage provides 60% of full capacity; 3rd stage provides 80% of full capacity; 4th stage provides 100% of full capacity.

Load Tracking Variable Capacity

Load tracking variable capacity will smoothly track the load (sensible temperature changes) up and down and adjust the furnace heating rate both ways.

Variable Capacity

Variable capacity only tracks the load upward (rising temperature). Variable capacity uses the iComfort® S30 stage differentials but not stage timers.

NUMBER OF GAS HEATING STAGES

This is applicable to the SLP98V only. Number of selectable stages when Gas Heat Control Mode is set in "Staged" mode. Options are 1 through 4. Default is 4.

UNDERSTANDING MODULATING STEP CHANGE AND STEADY STATE PI GAINS

Each of these terms has a multiplier (or gain) associated with it called the proportional gain and the integral gain respectively and affect responsiveness and stability

- **Standard** is a moderate gain suitable for nearly all installations.
- **More Aggressive** is a set of slightly higher gains that will make the system more responsive to changes, and will try harder to stay on the set point. This setting may cause some systems to oscillate.
- **Less Aggressive** is a set of slightly lower gains that will make the system less responsive and help to stabilize an oscillating system by sacrificing a small amount of time to set point.

None of the above options will cause the system to end a call if the demand for heating or cooling remains above the minimum capacity of the system since the algorithm is designed to find the demand that allows the system capacity to exactly match the house heating or cooling loss, creating a balance and constant temperature.

MODULATING GAS HEATING STEADY STATE PI GAIN (SLP98V ONLY)

This is applicable to the SLP98V only. Steady state gain controls the demand when the system is not responding to a sensed temperature change away from the iComfort® S30 setting.

Options are Less Aggressive, Standard and More Aggressive. Default is Standard. Recommend not changing this setting.

MODULATING GAS HEATING STEP CHANGE PI GAIN (SLP98V ONLY)

This is applicable to the SLP98V only. Step change gains deal with set point changes and affects how fast the system reaches the next set point (Example: Adjustment to the iComfort® S30 setting).

Options are Less Aggressive, Standard and More Aggressive. Default is Standard. Recommend not changing this setting.

MODULATING GAS HEATING CYCLES PER HOUR (SLP98V ONLY)

This feature is activated when the structure BTU load is less than the minimum Heat Pump heating capacity of the outdoor unit. The system will be cycled "ON" and "OFF" at the selected cycles per hour to maintain the settings of the iComfort® S30. (This governs how many cycles per hour the system will try to run when it needs to run at less than minimum capacity)

Range is 4 to 10 cycles. Default is 6 cycles. Adjustments are in increments of 0.5 cycles.

MODULATING HP HEATING STEADY STATE PI GAIN (XP20 AND XP25)

Steady state gain controls the demand when the system is not responding to a sensed temperature change away from the iComfort® S30 setting.

Options are Less Aggressive, Standard and More Aggressive. Default is Standard. Recommend not changing this setting.

MODULATING HP HEATING STEP CHANGE PI GAIN (XP20 AND XP25)

Step change gains deal with set point changes and affects how fast the system reaches the next set point (Example: Schedule change or adjustment to the iComfort® S30 setting).

Options are Less Aggressive, Standard and More Aggressive. Default is Standard. Recommend not changing this setting.

MODULATING HP HEATING CYCLES PER HOUR (XP20 AND XP25)

This is applicable to the XP25 only. This feature is activated when the structure BTU load is less than the minimum Heat Pump heating capacity of the outdoor unit. The system will be cycled "ON" and "OFF" at the selected cycles per hour to maintain the settings of the iComfort® S30. (This governs how many cycles per hour the system will try to run when it needs to run at less than minimum capacity)

Range is 3 to 6 cycles. Default is 4 cycles. Adjustments are in increments of 0.5 cycles.

AUX HEATING ACTIVATION THRESHOLD

This is an adjustment to hasten or delay the aux heat activation. This adjusts how far below the set point the temperature must fall with the HP at 100% before allowing electric heat to come on.

Range is 0 - 10°F with increments of 0.25°F. The default setting is 2.5°F.

COOLING MODE

Options are Normal and Comfort. Default is Normal. The normal setting cools the home to the desired temperature setting. Comfort is when a two-stage cooling system's 2nd stage is locked in until the demand is satisfied.

MODULATING COOLING STEADY STATE PI GAIN (XP20, XC20, XP25 AND XC25 ONLY)

Steady state gain controls the demand when the system is not responding to a sensed temperature change away from the iComfort® S30 setting. Options are less aggressive, standard and more aggressive Default is standard.

MODULATING COOLING CHANGE STATE PI GAIN (XP20, XC20, XP25 AND XC25 ONLY)

Step change gains deal with set point changes and affects how fast the system reaches the next set point

Options are less aggressive, standard and more aggressive Default is standard.

MODULATING COOLING CYCLES PER HOUR (XP20, XC20, XP25 AND XC25 ONLY)

This feature is activated when the structure BTU load is less than the minimum Heat Pump cooling capacity of the outdoor unit. The system will be cycled "ON" and "OFF" at the selected cycles per hour to maintain the settings of the iComfort® S30. (This governs how many cycles per hour the system will try to run when it needs to run at less than minimum capacity)

Range is 3 to 6 cycles hours. Can be adjusted in increments of 0.5. Default is 4.

TEMPERATURE CONTROL MODE

Options are Normal and Comfort. Default is Normal. The normal setting cools or heats the home to the desired temperature setting. Comfort is when a two-stage cooling system's 2nd stage is locked in until the demand is satisfied.

SINGLE SETPOINT MODE (NON-ZONING SYSTEMS ONLY)

Options are enabled or disabled. Default is disabled. The Single Set Point algorithm allows the user the set only one temperature set point value rather than one value for heating and a different value for cooling. When zoning is present, the following SSP settings are not available. When enabled the following parameters are automatically configured for optimal settings.

PARAMETERS	DESCRIPTIONS
SSP HEATING CANCEL COAST COUNTER INCREMENT SLOPE	Range is 0 to 0.75°F. Default is 0.25°F. Adjustments are in increments of 0.12°F
SSP HEATING CANCEL COAST COUNTER DECREMENT SLOPE	Range is 0.25 to 2°F. Default is 0.5°F. Adjustments are in increments of 0.12°F
SSP COOLING CANCEL COAST COUNTER INCREMENT SLOPE	Range is 0.75 to 0°F. Default is 0.25°F. Adjustments are in increments of 0.12°F.
SSP COOLING CANCEL COAST COUNTER DECREMENT SLOPE	Range is -2 to 0.25°F. Default is 0.5°F. Adjustments are in increments of 0.12°F.
SSP HEATING LOCKOUT OUTDOOR TEMP	When the outdoor temperature is above this setting, heating is not allowed if single set point is running. Range is 80 to 50°F. Default is 65°F. Adjustments are in increments of 1°F.
SSP COOLING LOCKOUT OUTDOOR TEMP	When the outdoor temperature is below this setting, cooling is not allowed if single set point is running. Range is 60 to 30°F. Default is 40°F. Adjustments are in increments of 1°F.

AUTO CHANGEOVER - TEMP DEADBAND

Prevents the Heating and Cooling from being set closer together than 3°F or greater than 9°F (Dead- band).

Range is 3 to 9°F. Default is 3°F. Adjustments are in increments of 1°F.

MAX HEAT SETPOINT

The highest temperature setting that the heat set point can be set on the iComfort® S30.

Range is 40 to 90°F. Default is 90°F. Adjustments are in increments of 1°F.

MIN COOL SETPOINT

The lowest temperature setting that the cool set point can be set on the iComfort® S30.

Range is 60 to 90°F. Default is 60°F. Adjustments are in increments of 1°F.

HEAT COOL STAGES LOCKED IN

Default is disabled (heat/cool stages are turned off separately). If changed to Enabled, heat/cool stages are turned off together. Options are enabled or disabled. Default is disabled.

1ST THROUGH 6TH STAGE DIFFERENTIALS

Number of stages in iComfort® S30 is dependent on equipment that is installed.

NOTE: XC/XP25 variable capacity systems will stage electric heat but not on differentials. It will use the iComfort® S30 PI logic to stage the electric heat). If the system has a variable capacity furnace or zoning all stage differentials will be ignored.

STAGE DELAY TIMERS

Enabled setting: When "ON" all stage delay timers (stages 2 through 6) are enabled and will serve to bring on additional stage(s) of cooling or heating on a timed basis (default 20 minutes) Disabled setting: All stages delay timers are disabled. Heat/cool stages are changed based on temperature.

NOTE: The second-stage delay timer (when stage timers is Enabled) is used for both HEATING and COOLING. However, if the system has a variable capacity furnace, zoning or variable outdoor unit, all stage delay timer will be ignored.

2ND THROUGH 6TH STAGE DELAYS

2nd thru 6th Stage Delay timer (where applicable) - If staged delay timers are "Enabled", the default is 20 minutes but can be programmed from 5 to 120 minutes in 5-minute increments. If the first stage fails to advance the ambient temperature toward the set point by 1.0°F in the programmed delay time, then the second stage is activated. However, if the system has a variable capacity furnace, zoning or variable outdoor unit, all stage delay timer will be ignored.

Range is 5 to 120 minutes. Default is 20 minutes. Adjustments are in increments of 5 minutes.

LOCK IN 2ND STAGE HP BY OUTDOOR TEMP (XP21 ONLY)

This accessory allows the unit to lock in 2nd stage HP heating when the outdoor temperature goes below the jumper pin setting.

Options are off, 40°F (4°C), 45°F (7°C), 50°F (10°C) and 55°F (13°C). Default is off.

BALANCE POINT CONTROL

If system is set up as dual fuel or heat pump and electric heat, the low and high balance point exists. The balance points feature requires that a sensed outdoor temperature is provided to the iComfort® S30.

NOTE: When balance point control is ENABLED, the low and high balance point fields will be turned "ON" and show RED. A message will be displayed asking you to review the low and high balance point settings and save all RED settings. Highlighted fields in RED must be saved to allow exit from that screen.

Options are enabled or disabled. Default is disabled. When enabled, both low and high balance points are controlled.

HIGH BALANCE POINT

Setting used to prevent the furnace or electric heat from heating the structure. (Alert 19 - Minor - Notification only - The outdoor temperature is higher than the level where the furnace or electric heat is programmed to heat the home.)

Range is 17 to 75°F. Default is 50°F. Adjustments are in increments of 1°F.

LOW BALANCE POINT

Setting used to prevent the heat pump from heating the structure. (Alert 18 - Minor - Notification only - The outdoor temperature is below the level where the heat pump is programmed to heat the home)

Range is 20 to 72°F. Default is 25°F. Adjustments are in increments of 1°F.

ELECTRIC HEAT STAGES DURING DEFROST

Can increase or decrease the number of electric elements to come on during a call for defrost. (iComfort® S30 will have a demand for heat.)

Range is 0 to 5 electric heat stages. Default is 2. Adjustments are in increments of 1.

MIN DEHUMIDIFICATION SETPOINT

Adjustable dehumidification range on the iComfort® S30.

Range is 40 to 60%. Default is 40%. Adjustments are in increments of 1%.

HUMIDITROL COMFORT ADJUST

Options are Maximum Overcooling, Midpoint Overcooling and Minimum Overcooling. Default is Maximum Overcooling.

- **Maximum Overcooling:** Indoor temperature > (greater than) 2°F above heating setpoint.
- **Midpoint Overcooling:** Indoor temperature > (greater than) HEAT setpoint + COOL setpoint / 2.
- **Minimum Overcooling:** Indoor temperature > (greater than) 2°F below cooling setpoint.

NOTE: XP25 is not currently compatible with Humiditrol (EDA).

MAX HUMIDIFICATION SETPOINT

Maximum allowed set point for humidification.

Range is 15 to 45%. Default is 45%. Adjustments are in increments of 1%.

DEW POINT ADJUSTMENT

Range is -15 to 15°F. Default is 0°F. Adjustments are in increments of 1°F.

The Dew Point Adjustment can be set from -15% to +15%. These settings allow adjustments to the Dew Point setting for the home. Some homes may require an adjustment to help maintain comfort. If condensation is present on windows, set the adjustment lower, between -15% to -5%. If the home feels dry, set the adjustment upwards, between +5 to +15%.

AUTO CHANGEOVER - HUMIDIF. DEADBAND

Prevents the Humidification and Dehumidification settings from being closer together than 5% or greater than 10% (Dead-band).

Range is 5 to 10%. Default is 5%. Adjustments are in increments of 1%.

OUTDOOR TEMPERATURE READING CALIBRATION

Range is -10 to 10°F. Default is 0°F. Adjustments are in increments of 1°F. This will allow for adjustment to the outdoor temperature display when the display temperature is off. Outdoor sensor is required.

HP HEATING MODE (XP25 ONLY)

Options are Normal and Comfort. Default is Normal. The normal setting heats the home to the desired temperature setting. Modify the heating comfort mode to limit minimum compressor speed to 60 – 70 percent range and/or adjust comfort mode CFM.

AUTO DEHUMIDIFICATION OVERCOOLING THRESHOLD

Range is 0 - 10°F. Default is 4°F. Adjustments are in increments of 4°F.

SEVERE WEATHER PROTECTION

Options are enabled or disabled. Default is enabled. When enabled both the heat and freezing alert temperature settings will cool or heat the home based on the setting of both parameters.

HEAT ALERT TEMPERATURE

This will turn on the cooling system when the indoor temperature reaches the setting defined for this parameter. Range is 80°F to 120°F with a factory default of 100°F.

FREEZING ALERT TEMPERATURE

This will turn on the heating system when the indoor temperature reaches the setting defined for this parameter. Range is 20°F to 60°F with a factory default of 40°F.

ZONING GAS HEATING DAT COOLDOWN TARGET

At the end of a gas cycle, the Heat Blower Off-Delay may not be long enough to completely cool the heat exchanger. This may result in a primary limit trip then, or at the beginning of the next heat demand. This parameter allows the blower to run after a gas heat call ends until the discharge air temperature sensor (DATS) cools to the temperature set in the parameter. If the temperature is set too low this will cause the temperature in the room to overshoot.

Range is 80 to 90°F. Default is 85°F. Adjustments are in increments of 1°F.

ZONING ANTICIPATED DISCHARGE AIR TEMPERATURE ADJUSTMENT

This parameter setting compensates for a rapid change of the discharge air temperature due to fast changing conditions. It examines the change in the discharge air temperature for the previous 2 minutes and extrapolates or looks forward by the number of seconds set in the parameter and uses this as the DATS value for staging. This parameter setting helps prevent limit trip/frozen coil from occurring.

Range is 0 to 120 seconds. Default is 60 seconds. Adjustments are in increments of 5 seconds.

ZONING TARGET SUPPLY AIR TEMP FOR COOLING

In cooling mode, this setting sets the target discharge air temperature.

Range is 40 to 60°F. Default is 45°F. Adjustments are in increments of 1°F.

ZONING TARGET SUPPLY AIR TEMP FOR HP HEATING

In heat pump heating mode, this setting sets the target discharge air temperature.

Range is 85 to 110°F. Default is 90°F. Adjustments are in increments of 1°F.

ZONING SUPPLY AIR TEMP LIMIT FOR COOLING

In cooling mode, this setting sets the discharge air temperature low limit. Below this temperature, the cooling is turned off.

Range is 35 to 45°F. Default is 40°F. Adjustments are in increments of 1°F.

ZONING SUPPLY AIR TEMP LIMIT FOR GAS/ELECTRIC HEATING

In heating mode, this setting sets the target discharge air temperature.

Range is 140 to 160°F. Default is 140°F. Adjustments are in increments of 5°F.

HP HEATING LOCKOUT TIME

The HP could not get a zone to progress 0.5°F towards the set point in 120 minutes (Code 40 - Minor alert). System will switch to secondary heat source. (Electric heat or furnace in dual fuel applications). Transition back to Heat Pump normal operation when termination setting times out.

Range is 60 to 240 minutes. Default is 120 minutes. Adjustments are in increments of 30 minutes.

ZONING MINIMUM ZONE RUN TIME

Range is 90 to 600 seconds. Default is 120 seconds. Adjustments are in increments of 30 seconds.

ZONE 1 THROUGH 4 FIRST STAGE DIFFERENTIAL

Differential is the temperature between when first stage will cycle ON and cycle OFF. (Example: Zone 1 HD Display is set at 70°F with a 1.0°F differential. Cooling Demand - cooling will cycle ON when the room temperature reaches 70.5°F and cycle OFF when the room temperature is 69.5°F)

Range is 0.5 to 3°F. Default is 1°F. Adjustments are in increments of 1°F.

NOTE: For XC/XP 25 differentials are ignored.

ZONE 1 THROUGH 4 CONTINUOUS BLOWER CFM

Minimum and maximum CFM will be dependent on system component configurations. These parameter values are automatically adjusted to the specific hardware configuration. See iHarmony® zoning system installation instruction for minimum CFMs for specific indoor units.

Zones requesting the fan ON are only allowed while no other zone demand is present. The iComfort® S30 will sum all the zone continuous blower CFM requirements and send the command only after positioning the dampers and waiting for the damper close delay period to expire (30 seconds) Continuous blower demands are the lowest priority demands, all other conditioning demands will over-ride the continuous blower demand.

Range is 5 to maximum of indoor unit. Default is dependent on tonnage of indoor unit. Adjustments are in increments of 5 CFM.

ZONE 1 THROUGH 4 COOLING CFM

Minimum and maximum CFM will be dependent on system component configurations. These parameter values are automatically adjusted to the specific hardware configuration. See iHarmony® zoning system installation instruction for minimum CFMs for specific indoor units.

Target cooling CFM for a specific zone. Range is 5 to maximum of indoor unit. Default is dependent on tonnage of indoor unit. Adjustments are in increments of 5 CFM. Adjustments are in increments of 5 CFM.

ZONE 1 THROUGH 4 HEATING CFM

Minimum and maximum CFM will be dependent on system component configurations. These parameter values are automatically adjusted to the specific hardware configuration (See table 9 in iHarmony installation instructions or on the right side of this page for minimum CFMs for specific indoor units.

Target heating CFM for a specific zone. Range is 5 to maximum of indoor unit. Default is dependent on tonnage of indoor unit. Adjustments are in increments of 5 CFM. Adjustments are in increments of 5 CFM.

ADVANCED SETTINGS

Options available are:

- Restart Smart Hub (reboots Smart Hub).
- Reset Smart Hub (erases Smart Hub settings and restarts installer setup).
- Reconfigure system (erases all system settings and restarts installer setup).

HEAT PUMP

The following is information on all possible available parameters. Parameters listed are dependent on actual type of heat pump installed.

ABOUT

This screen provides information concerning language supported, equipment type name, unit model number, unit serial number, unit nominal capacity, number of heating states, number of cooling stages, heating capacity by stage, cooling capacity by stage, control software revision, control model number, control serial number, control hardware revision, outdoor air temp sensor, protocol revision number, device product level, 24VAC average power consumption, 24VAC peak power consumption, line voltage average power consumption, line voltage peak power consumption, outdoor inverter model number, outdoor inverter firmware version, outdoor fan RPM profile, unit code, compatible devices list, application code memory size and micro-controller part number.

EQUIPMENT NAME

A unique name can be assigned to this component. Name can be up to 29 characters. Name can consist of letters, numbers, special characters and spaces.

COMPRESSOR SHORT CYCLE DELAY

The range is 60 - 300 seconds. Default is 300 seconds and with an incremental adjustment of 60 seconds.

This feature prevents the compressor from being short cycled any time the compressor is turned "OFF"

DEFROST TERMINATION TEMP

The range is 50 - 100°F. Default is 50°F and with an incremental adjustment of 10°F.

This is the temperature that defrost mode will be terminated.

COMPRESSOR SHIFT DELAY ON/OFF

The options are ON or OFF. By default it is set to ON.

- Shift Delay "OFF" - Compressor will not be cycled "OFF" going in and out of defrost.
- Shift Delay "ON" - Compressor will be cycled "OFF" going in and out of defrost.

HIGH NORMAL COOLING AIRFLOW (XP20 AND XP25)

The range is 450 - 2150 CFM. Default is dependent on unit capacity with an incremental adjustment of 25 CFM.

iComfort® S30 values shown are defaults. This value can be adjusted up or down to meet each application requirements.

LOW NORMAL COOLING AIRFLOW (XP20 AND XP25)

The range is 450 - 2150 CFM. Default is dependent on unit capacity with an incremental adjustment of 25 CFM.

iComfort® S30 values shown are defaults. This value can be adjusted up or down to meet each application requirements.

HIGH NORMAL HP HEATING AIRFLOW (XP20 AND XP25)

The range is 450 - 2150 CFM. Default is dependent on unit capacity with an incremental adjustment of 25 CFM.

iComfort® S30 values shown are defaults. This value can be adjusted up or down to meet each application requirements.

LOW NORMAL HP HEATING AIRFLOW (XP20 AND XP25)

The range is 450 - 2150 CFM. Default is dependent on unit capacity with an incremental adjustment of 25 CFM.

iComfort® S30 values shown are defaults. This value can be adjusted up or down to meet each application requirements.

DEHUM AIRFLOW ADJUSTMENT ADDER (XP20 AND XP25 ONLY)

Dehumidification airflow = "HUMID" Mode CFM table value for a given iComfort® S30 demand + dehumidification adjustment adder (High Normal Cooling Airflow CFM x Dehumidification Airflow Adjustment Adder in percentage. Both these values are in the installer set up under System Device/Heat Pump High Normal Cooling Airflow).

NOTE: Deactivated in auxiliary dehumidification and Enhanced Dehumidification Accessory (Humiditrol)

FAN CYCLING

Options are ON or OFF. Default OFF.

MAX DEFROST

This option has two settings, either ON or OFF. Default is OFF. When set to ON, the system will always run at MAX DEFROST when accumulated compressor off time is longer than 30 minutes and ambient temperature is less than 35°F. When ambient sensor temperature is higher than 40°F then defrost termination will be 90°F.

RESET HEAT PUMP

Any installer modifications under the heat pump tab will be reset back to the factory defaults if the reset heat pump option is used.

AIR CONDITIONER

The following is information on all possible available parameters. Parameters listed are dependent on actual type of air conditioner installed.

ABOUT

This screen provides information concerning language supported, equipment type name, unit model number, unit serial number, unit nominal capacity, number of cooling stages, cooling capacity by stage, control software revision, control model number, control serial number, control hardware revision, outdoor air temp sensor, protocol revision number, device product level, 24VAC average power consumption, 24VAC peak power consumption, line voltage average power consumption, line voltage peak power consumption, outdoor inverter model number, outdoor inverter firmware version, outdoor fan RPM profile, unit code, compatible devices list, application code memory size and micro-controller part number.

EQUIPMENT NAME

A unique name can be assigned to this component. Name can be up to 29 characters. Name can consist of letters, numbers, special characters and spaces.

COMPRESSOR SHORT CYCLE DELAY

The range is 60 - 300 seconds. Default is 300 seconds and with an incremental adjustment of 60 seconds.

This feature prevents the compressor from being short cycled any time the compressor is turned "OFF"

HIGH NORMAL COOLING AIRFLOW (XC20, AND XC25 ONLY)

The range is 450 - 2150 CFM. Default is dependent on unit capacity with an incremental adjustment of 25 CFM.

iComfort® S30 values shown are defaults. This value can be adjusted up or down to meet each application requirements.

LOW NORMAL COOLING AIRFLOW (XC20, AND XC25 ONLY)

The range is 450 - 2150 CFM. Default is dependent on unit capacity with an incremental adjustment of 25 CFM.

iComfort® S30 values shown are defaults. This value can be adjusted up or down to meet each application requirements.

DEHUM AIRFLOW ADJUSTMENT ADDER (XC20, AND XC25 ONLY)

Dehumidification airflow = "HUMID" Mode CFM table value for a given iComfort® S30 demand + dehumidification adjustment adder (High Normal Cooling Airflow CFM x Dehumidification Airflow Adjustment Adder in percentage. Both these values are in the installer set up under System Device/Air Conditioner/High Normal Cooling Airflow).

NOTE: Deactivated in auxiliary dehumidification and Enhanced Dehumidification Accessory (Humiditrol)

RESET BUTTON

Any installer modifications under the air conditioner tab will be reset back to the factory defaults if the reset air conditioner option is used.

AIR HANDLER

The following is information on all possible available parameters for Lennox communicating air handlers.

ABOUT

Provides information concerning unit code, language support, equipment type name, unit model number, unit serial number, unit nominal capacity, number of heating states, heating capacity by stage, indoor blower CFM range, control software revision, control model number, control serial number, control hardware revision, discharge air temp sensor, outdoor air temp sensor, protocol revision number, device product level, factory installed transformer, 24VAC average power consumption, 24VAC peak power consumption, line voltage average power consumption, line voltage peak power consumption, compatible devices list, applicable code memory size, and micro-controller part number.

EQUIPMENT NAME

A unique name can be assigned to this component. Name can be up to 29 characters. Name can consist of letters, numbers, special characters and spaces.

ELECTRIC HEATING AIRFLOW

The range is 1560 to 2150 CFM. Default is dependent on unit capacity with an incremental adjustment of 5 CFM.

Range of operation of the indoor blower during electric heat operation

HIGH COOLING AIRFLOW

The range is 1560 to 2150 CFM. Default is based on cooling demand with an Incremental adjustments of 5 CFM.

Range of operation of the indoor blower during high cooling operation.

AIRFLOW PROFILE - COOLING

Options are:

- 1 - no delays
- 2 - ON: 100% - finish cycle - 45 second delay off.
- 3 - ON: 82% - 7-1/2 minutes at 100% and finish cycle off.
- 4 - ON: 50% - 30 seconds at 82% - 7-1/2 minutes at 100% and finish cycle 50% / 30 seconds off.

HIGH HP AIRFLOW

The range is 800 -1100 CFM. Default setting is depending on unit tonnage. Can be incrementally adjusted by 25 CFM.

Range of operation of the indoor blower during high heat pump operation.

CONTINUOUS INDOOR BLOWER AIRFLOW

The range is 450 to 2150 CFM. Default is dependent on component match-up. Incremental adjustments are made in 5 CFM.

Range of operation of the indoor blower during continuous blower operation.

HEATING INDOOR BLOWER OFF DELAY

The range is 0 - 10 seconds. Default is 10 seconds with an incremental adjustment of 1 second.

Heating Indoor Blower OFF Delay (Electric Heat only -Blower runs at continuous air CFM setting during delay timing period)

HEATING INDOOR BLOWER ON DELAY

The range is 0 - 5 seconds. Default is 0 seconds with an incremental adjustment of 1 second.

COOLING INDOOR BLOWER OFF DELAY

The range is 0 - 30 seconds. Default is 0 seconds with an incremental adjustment of 2 seconds.

COOLING INDOOR BLOWER ON DELAY

The range is 0 - 10 seconds. Default is 2 seconds with an incremental adjustment of 1 second.

HP INDOOR BLOWER OFF DELAY

The range is 0 - 60 seconds. Default is 45 seconds with an incremental adjustment of 5 seconds.

Heat Pump Indoor Blower OFF Delay (Heat Pump only - Blower runs at continuous air CFM setting during delay timing period)

HP INDOOR BLOWER ON DELAY

The range is 0 - 30 seconds. Default is 0 seconds with an incremental adjustment of 5 seconds.

RESET AIR HANDLER

Any installer modifications under the air handler tab will be reset back to the factory defaults if the reset air handler option is used.

FURNACE

ABOUT

This screen provides information on unit code, language supported, equipment type name, unit model number, unit serial number, unit nominal capacity, number of heating stages, heating capacity by stage, indoor blower CFM range, control software revision, control model number, control serial number, control hardware revision, discharge air temp sensor, outdoor air temp sensor, protocol revision number, device product level, factory installed transformer, 24VAC average power consumption, 24VAC peak power consumption, line voltage average power consumption, line voltage peak power consumption, compatible devices list, application code memory size and micro-controller part number.

EQUIPMENT NAME

A unique name can be assigned to this component. Name can be up to 29 characters. Name can consist of letters, numbers, special characters and spaces.

CONTINUOUS INDOOR BLOWER AIRFLOW

The range is 450 - 2000 CFM with a default setting based on equipment type match-up. Adjustments are in increments of 5 CFM

NOTE: All communicating installer parameters default CFM values based on DIP switch setting (non-communicating value) prior to power up are use and calculated using the CFM conversion tables and rounded up to closest number on 25 CFM resolution. Any DIP switch changes made after power up are ignore.

HEATING INDOOR BLOWER OFF DELAY

The range is 6 - 180 seconds with a default setting base on equipment type match-up. Adjustment are increments of 10 seconds.

HEATING INDOOR BLOWER ON DELAY

The range is 15 - 45 seconds with a default setting base on equipment type match-up. Adjustment are increments of 5 seconds.

HEATING AIRFLOW CONTROL TYPE

Options for this setting are fixed CFM or fixed DAT (discharge air temperature). Default is dependent on equipment type match-up.

Fixed CFM is selected as the Heating Airflow Control Type (parameter default selection), the circulator will operate at a CFM that is linearly interpolated between Low Heating Airflow and High Heating Airflow based on the current IFC firing rate. For example, if the firing rate is 60% and Low Heating Airflow and High Heating Airflow were set to 500 CFM and 900 CFM respectively (both parameter values are set during the IFC commission), the circulator will run at 633 CFM ($= 500 + (900-500) * (60-40)/(100-40)$) – assuming 40% minimum fire rate

Fixed Discharge Air Temperature (DAT) control when selected as Heating Airflow Control Type, the IFC will vary circulator at a CFM to maintain a set Discharge Air Temperature (DAT). For example if the firing rate is 60% and Low Heating DAT and High Heating DAT were set to 120°F and 130°F respectively (both parameter values are set during the IFC commission), the IFC will control the circulator to maintain a DAT at 120°F ($115 + (130-115) * (60-40)/(100-40)$) – assuming 40% minimum fire rate.

When Fix DAT is enabled, the following parameters are available:

Parameter Name	Description
Low Heating Discharge Temp	Range is 105 to 135°F. Adjustable in increments of 5F. Default is 120°F.
High heating Discharge Temp	Range is 115 to 145°F. Adjustable in increments of 5F. Default is 130°F.

LOW HEATING AIRFLOW

The range is 500 - 700 CFM with a default setting based on equipment type match-up. Adjustments are in increments of 25 CFM. This value is automatically adjusted by the system based on heating airflow control type used.

HIGH HEATING AIRFLOW

The range is 1150 - 1575 CFM with a default setting based on equipment type match-up. Adjustments are in increments of 25 CFM. This value is automatically adjusted by the system based on heating airflow control type used.

RESET FURNACE

Any installer modifications under the furnace tab will be reset back to the factory defaults if the reset furnace option is used.

THERMOSTAT (HD DISPLAY)

ABOUT

This screen provides information concerning model number, serial number, hardware revision, software revision, language support and equipment type name.

SCREEN LOCKED

Options are unlocked, partially locked and locked. Default is unlocked.

DISPLAY OUTDOOR WEATHER

Options are on and off. Default is off.

DISPLAY AIR QUALITY

Options are on and off. Default is off. Air Quality is displayed under the weather display. Press the Weather icon on the home page to see the current air quality.

OUTDOOR TEMPERATURE

Options are Internet, sensor or off. Default is sensor.

DISPLAY INDOOR HUMIDITY

Options are on and off. Default is off.

SCREEN SAVER

Options are off, weather, power save and picture. Default is off.

AUTO BRIGHTNESS

Options are on and off. Default is off.

BRIGHTNESS VALUE

The brightness range is 0 - 100. Default 80. Press either the + or - button to increase or decrease the setting.

PROXIMITY CONTROL

Options are ON and OFF. Default is OFF. This is used to determine if the home is occupied.

RESET THERMOSTAT

Any installer modifications under the thermostat tab will be reset back to the factory defaults if the reset thermostat option is used.

ZONING CONTROL

ABOUT

This provides information on unit code, language supported, equipment type name, control software revision, control model number, control serial number, control hardware revision, protocol revision number, device product level, 24VAC average power consumption, 24VAC peak power consumption, compatible devices list, application code memory size, micro-controller part number, max number of zones, supported damper types, number of damper positions, zone temp sensor 1, zone temp sensor 2, zone temp sensor 3 and zone temp sensor 4.

EQUIPMENT NAME

A unique name can be assigned to this component. Name can be up to 29 characters. Name can consist of letters, numbers, special characters and spaces.

ZONES 1 THROUGH 4 TEMP READING CALIBRATION

Allows adjustment to temperature reading displayed on zone thermostat.

RESET ZONING CONTROL

Any installer modifications under the zoning control tab will be reset back to the factory defaults if the reset zoning control option is used.

ADD / REMOVE EQUIPMENT

This selection allows the installer to add or remove non-communicating equipment such as outdoor units, humidifiers and dehumidifiers.

RESET ALL EQUIPMENT

Using this option will reset all equipment back to its original factory default settings. The installer setup sequence will start as well.



NOTIFICATIONS

These screens provide information on active notifications and previously cleared notifications. When selecting either a cleared or active notification a brief description and alert code will be displayed. Notifications are categorized by system, indoor unit (air handler or furnace), outdoor unit (air conditioner or heat pump), zoning control (if installed) and iComfort® S30.

To expand a specification notification to access a more detail description of the alert code, press the down arrow to expand the description. See table 1 for details on alert codes and troubleshooting advice.

Table 1. Alert Codes and Troubleshooting				Critical alerts are displayed on the Home screen, in the Homeowner alert button, and in the Installer alert button. Minor and moderate alerts are found only in the Installer alert button.	
Alert Code	Priority Condition	Applicable System Components	Alert Text	Component or System Operational State and Troubleshooting Tip	How to clear alert code
10	Critical	S30, air handler, furnace, outdoor unit, equipment interface and iHarmony damper control modules.	The thermostat has found an unknown device on the system.	<p>The iComfort® S30 when not in configuration mode has detected an unknown device.</p> <p>Typically the thermostat will send a command to the unknown device and place it in a soft disable state.</p> <p>The iComfort control with the soft disable state will indicate so as follows:</p> <ul style="list-style-type: none"> ▶ On air handler, furnace and outdoor controls, the state is displayed by double horizontal lines on seven-segment display. ▶ On the damper control module, the green LED will blink 3 seconds on and 1 second off. ▶ On the equipment interface module, the green LED will blink 3 seconds on and 1 second off. <p>Cycling power to the soft disabled control may clear the condition. If cycling power does not clear the soft disable state then replace control.</p>	Clear alert code by reconfiguring the system.
11	Critical	S30	The thermostat cannot find a previously installed system component.	<ul style="list-style-type: none"> ▶ Check all connections and cycle system power. ▶ Press the setup tab, press start, and press confirm. ▶ If problem persists, then check all system components (devices) connections to make sure they are iComfort®-compatible. 	If problem persists, clear by reconfiguring the system
12	Critical	S30, furnace, equipment interface module or air handler	The thermostat cannot find an iComfort® indoor unit.	<ul style="list-style-type: none"> ▶ Thermostat did not find an indoor unit. Make sure there is an iComfort® indoor unit on the system. Check R, i+, i- and C connections and voltages. ▶ Ohm wires and cycle power. ▶ Replace indoor unit control if there is no response. ▶ Check for voltage and missing component. 	Automatically clears when the system detects that the issue no longer exists.
13	Critical	S30	Duplicate Comfort Sensor Identification	<ul style="list-style-type: none"> ▶ S30 Control System found more than one outdoor unit, or more than one indoor unit, or more than one thermostat connected to the system. S03 Control System will shall display the message "Too Many Devices of the Same Type". 	The action required to clear/recover shall be: Check wiring and remove duplicate equipment. Reconfigure system.
14	Critical	S30	The thermostat found more than one thermostat, indoor or outdoor unit on the system.	<ul style="list-style-type: none"> ▶ Check wiring and remove duplicate equipment. ▶ Reconfigure system. 	Automatically clears when the system detects that the issue no longer exists.

Table 1. Alert Codes and Troubleshooting				Critical alerts are displayed on the Home screen, in the Homeowner alert button, and in the Installer alert button. Minor and moderate alerts are found only in the Installer alert button.	
Alert Code	Priority Condition	Applicable System Components	Alert Text	Component or System Operational State and Troubleshooting Tip	How to clear alert code
18	Minor	S30	The outside temperature is below the level where the heat pump is programmed to heat the home.	<ul style="list-style-type: none"> ▶ The system will not use the heat pump to warm your home. ▶ Outdoor temperature is below the low balance point. ▶ Heat pump will not be used to service a heating demand. 	This is a notification only alert code.
19	Minor	S30	The outside temperature is higher than the level where the furnace or electric heat is programmed to work.	<ul style="list-style-type: none"> ▶ The system will only use the heat pump to warm your home ▶ This is a notification only alert code. ▶ Outdoor temperature is above the low balance point. ▶ Indoor unit (furnace or air handler) will not be used to service a heating demand. 	Automatically clears when the system detects that the issue no longer exists.
29	Critical	S30	The thermostat is reading an indoor temperature that is higher than 99°F. The thermostat will not allow any heating operation to begin until it senses an indoor temperature lower than 99°F.	<ul style="list-style-type: none"> ▶ Indoor temperature rose above 99°F during a heating or cooling demand. ▶ Heating operation is not allowed. ▶ Check to ensure that heating equipment is not stuck ON (reversing valve, etc.). ▶ Check the accuracy of the thermostat temperature sensor. ▶ Select cooling system mode to cool the indoor space. 	Automatically clears when the system detects that the issue no longer exists.
30	Moderate	S30	The thermostat is reading an indoor temperature that is lower than 40°F.	<ul style="list-style-type: none"> ▶ The thermostat will not allow any cooling operation to begin until it senses a temperature higher than 40°F. ▶ Indoor temperature fell below 40°F. ▶ Cooling operation is not allowed. ▶ Check to ensure that cooling equipment is not stuck ON. ▶ Check accuracy of the thermostat temperature sensor. ▶ Select heating system mode to heat the indoor space to above 40°F. 	Automatically clears when the system detects that the issue no longer exists.
31	Critical	S30	The thermostat has lost communication with a system component for more than three minutes.	<ul style="list-style-type: none"> ▶ The applicable system component (indoor, equipment interface or damper control module or outdoor unit) has not communicated with thermostat for more than three minutes. ▶ Check connections and voltages. ▶ Ohm wires. 	If fault persists, then cycle power. Fault clears after communication is restored.
32	Moderate	S30, furnace, air handler or outdoor unit	The applicable system component (device) is re-setting itself.	<p>This issue may occur during a power outage or power fluctuation in the system. If persistent or if it coincides with the system operations then proceed with the following troubleshooting steps.</p> <ul style="list-style-type: none"> ▶ Check the power connections ▶ Check the amp draw at the transformer (the transformer maybe overloaded) ▶ Check 24VAC voltage at the system component (device). <p>If the fault persists after checking the connections, replace the unit's control board.</p>	This alert code is cleared by pressing the clear button on the Installer Alerts Tab.
34	Critical	S30	The thermostat does not know the capacity (tonnage) of the indoor or outdoor unit.	<ul style="list-style-type: none"> ▶ The applicable system component is missing the programmed unit capacity. ▶ Go to applicable system component and program the unit capacity manually (see the unit installation instruction for programming instructions). ▶ Remove power to thermostat before programming the unit control. ▶ Once programming is complete, reconnect thermostat wires and reconfigure system. 	Automatically clears when the system detects that the issue no longer exists.

Critical alerts are displayed on the Home screen, in the Homeowner alert button, and in the Installer alert button. Minor and moderate alerts are found only in the Installer alert button.

Table 1. Alert Codes and Troubleshooting

Alert Code	Priority Condition	Applicable System Components	Alert Text	Component or System Operational State and Troubleshooting Tip	How to clear alert code
36	Critical	S30	The system has been heating for at least 15 minutes without a demand for heating.	<ul style="list-style-type: none"> ▶ Run the system in diagnostic mode and verify that it matches actual equipment operation. ▶ Check for other alert codes that may be preventing the system from operating as expected. ▶ Check all heating equipment to determine cause of heating demand. ▶ Recycle power. 	Automatically clears when the system detects that the issue no longer exists.
37	Critical	S30	The system has been cooling for at least 15 minutes, without a demand for cooling.	<ul style="list-style-type: none"> ▶ Run the system in diagnostic mode and verify that it matches actual equipment operation. ▶ Check for other alert codes that may be preventing the system from operating as expected. ▶ Check all cooling equipment to determine cause of cooling demand. ▶ Recycle power. 	Automatically clears when the system detects that the issue no longer exists.
38	Critical	S30	The system has not been able to turn on the heating for more than 45 minutes.	<ul style="list-style-type: none"> ▶ The system will go offline for 60 minutes and will attempt to restart itself. ▶ Run the system in diagnostic mode and verify that it matches actual equipment operation. ▶ Check for other alert codes that may be preventing the system from operating as expected. ▶ Check all heating equipment to determine cause. ▶ Recycle power. 	Automatically clears when the system detects that the issue no longer exists.
39	Critical	S30	The system has not been able to turn on the cooling for more than 45 minutes.	<ul style="list-style-type: none"> ▶ The system will go offline for 60 minutes and will attempt to restart itself. ▶ Run the system in diagnostic mode and verify that it matches actual equipment operation. ▶ Check for other alert codes that may be preventing the system from operating as expected. ▶ Check all cooling equipment to determine cause. ▶ Recycle power. 	This alert code will automatically clear when the system detects the issue has no longer exists.

Critical alerts are displayed on the Home screen, in the Homeowner alert button, and in the Installer alert button. Minor and moderate alerts are found only in the Installer alert button.

Table 1. Alert Codes and Troubleshooting

Alert Code	Priority Condition	Applicable System Components	Alert Text	Component or System Operational State and Troubleshooting Tip	How to clear alert code
40	Minor	Outdoor Unit	<p>The HP could not progress the room temperature 0.5°F towards the set point in 30 minutes.</p> <p>System will switch to secondary heat source.</p> <p>(Secondary source is electric heat or furnace in dual -fuel applications).</p> <p>(Software issue: The issue is the 30-minute timer is not resetting to 30 minutes when the temperature rises 0.5°F.</p> <p>After 30 minutes, it causes alarm 40 to be set (erroneously), and the heat pump goes into the "HP heating Lockout Time" mode which indicates that the heat pump could be off for a maximum of 120 minutes. Range can be set between 60 to 120 minutes)</p>	<ul style="list-style-type: none"> ▶ The heat pump locks out on the "HP heating Lockout Time" setting in the HD Display "Installer/System Devices / Heat Pump screen" (Default is 120 minutes). The issue is the heat pump could not progress the room temperature by 0.5F towards the set point in 30 minutes. ▶ Set the low balance point and high balance point as close together as possible. (This is 3°F difference – Example: set high balance point at 35°F and low balance point would set at 32F). ▶ Below the low balance point, the furnace will heat the home / between the low and high balance point, the heat pump and furnace will heat the home. ▶ If the heat pump cannot raise the temperature 0.5°F in 30 minutes on the zone or zones, the "HP heating Lockout Time" (Location: Installer set/System devices/HP heating Lockout Time / default is 120 minutes) will lock the heat pump off when the outdoor temperature is above the high balance point. ▶ The gas furnace will finish the heating cycle. ▶ The gas furnace is locked out and all the heat is provided by the heat pump. 	<p>Clears when heat pump comes out of "HP heating Lockout Time" timer setting (Range can be set between 60 to 120 minutes. Default is 120 minutes).</p>
105	Critical	S30, furnace, air handler, outdoor unit, equipment interface or Harmony damper control module	<p>A system component has lost communication with the system.</p>	<ul style="list-style-type: none"> ▶ System component (device) is unable to communicate. ▶ This may indicate the existence of other active alert codes. ▶ In most cases errors are related to electrical noise. Verify that high voltage power is separated from the low voltage communication wires. ▶ Check for incorrectly wired or loose connections between system components (devices). ▶ Check for a high voltage source of noise close to the system. 	<p>Automatically clears when the system detects the issue no longer exists.</p>
110	Critical	Furnace	<p>The component line voltage is too low.</p>	<ul style="list-style-type: none"> ▶ This alert code may appear during a brownout. ▶ Line voltage is below its designed operating value. ▶ Check and correct the power line voltage. 	<p>Automatically clears when the system detects the issue no longer exists.</p>
111	Critical	Furnace	<p>The component line power voltage wiring is reversed.</p>	<ul style="list-style-type: none"> ▶ The unit is reporting that its power and neutral lines are reversed. ▶ Turn off the power to the system and correct the line power voltage wiring. ▶ System resumes normal operation five seconds after critical condition is recovered. 	<p>Automatically clears when the system detects the issue no longer exists.</p>
112	Critical	Furnace	<p>The reporting component cannot find earth ground.</p>	<ul style="list-style-type: none"> ▶ The thermostat will shut down the system. ▶ Provide proper earth ground to the equipment. ▶ System resumes normal operation five seconds after critical condition is recovered. 	<p>Automatically clears when the system detects the issue no longer exists.</p>

Table 1. Alert Codes and Troubleshooting				Critical alerts are displayed on the Home screen, in the Homeowner alert button, and in the Installer alert button. Minor and moderate alerts are found only in the Installer alert button.	
Alert Code	Priority Condition	Applicable System Components	Alert Text	Component or System Operational State and Troubleshooting Tip	How to clear alert code
113	Critical	Furnace	The line voltage is too high.	<ul style="list-style-type: none"> ▶ Line voltage high (voltage higher than nameplate rating). ▶ Provide power voltage within proper range. ▶ System resumes normal operation five seconds after critical condition is recovered. 	Automatically clears when the system detects the issue no longer exists.
114	Moderate / Critical	Furnace, air handler, equipment interface or Harmony damper control module	There is a frequency / distortion problem with the power to a specific system component.	<ul style="list-style-type: none"> ▶ This alert code may indicate transformer overloading. ▶ Check the voltage and line power frequency. ▶ Check the generator operating frequency, if the system is running on back-up power. ▶ Correct voltage and frequency problems. ▶ System will resume normal operation five seconds after fault recovered. ▶ All applicable system component outputs are disabled – moderate condition. ▶ After 10 minutes, the priority condition is escalated – critical condition. ▶ Damper control module will operate in central mode only until proper voltage is restored or frequency distortion is resolved – moderate condition. 	Automatically clears when the system detects the issue no longer exists.
115	Critical	Furnace, air handler or equipment interface module	Primary 24VAC power to a system component control is lower than the required range of 18 to 30VAC.	<ul style="list-style-type: none"> ▶ Primary 24VAC voltage is low (range is 18 to 30 volts). ▶ Check and correct voltage. ▶ Check for additional power-robbing system components (devices) connected to system. ▶ This alert code may require the installation of an additional or larger VA transformer. 	Automatically clears when the system detects the issue no longer exists.
115	Critical	Harmony Damper control module	Secondary 24VAC power to the damper control module is low.	<ul style="list-style-type: none"> ▶ Secondary 24VAC voltage is low (range is 18 to 30 volts). ▶ Check and correct voltage. ▶ Check for additional power-robbing equipment connected to system. ▶ This alert code may require the installation of an additional or larger VA transformer. ▶ Damper control module will operate in non-zone mode until proper voltage is restored. 	Automatically clears when the system detects the issue no longer exists.
116	Critical	Furnace or Air Handler	High secondary (24VAC) voltage	<ul style="list-style-type: none"> ▶ IComfort® S30 Control system will display this code when 24VAC power is high (18 to 30 VAC). ▶ Will display Furnace or Air Handler High Secondary (24VAC) voltage. 	Check and correct voltage. Check for proper line voltage (120V, 240V, etc.) to equipment. Clears when control senses proper voltage.
117	Minor	Furnace	The reporting unit has poor earth grounding.	<ul style="list-style-type: none"> ▶ Provide proper grounding for the system component (device). ▶ Check for proper earth ground to the system. 	Automatically clears 30 seconds after the issue is corrected.
120	Moderate	S30, furnace, air handler, outdoor unit, equipment interface or Harmony damper control module	There is a delay in the system component responding to the system.	<ul style="list-style-type: none"> ▶ Typically this alert code does not cause any operational issues and will clear on its own. ▶ This alert code is usually caused by a delay in the outdoor unit responding to the thermostat. ▶ Check all wiring connections. 	Automatically clears after an unresponsive system component (device) responds to any inquiry.

Table 1. Alert Codes and Troubleshooting				Critical alerts are displayed on the Home screen, in the Homeowner alert button, and in the Installer alert button. Minor and moderate alerts are found only in the Installer alert button.	
Alert Code	Priority Condition	Applicable System Components	Alert Text	Component or System Operational State and Troubleshooting Tip	How to clear alert code
124	Critical	S30, furnace, air handler, outdoor unit, equipment interface or IHarmony damper control module	The thermostat has lost communication with a system component for more than three minutes.	<ul style="list-style-type: none"> ▶ System component has lost communication with the thermostat. ▶ Check the wiring connections. ▶ Ohm wires. ▶ Cycle power. ▶ Check voltage at component. ▶ This alert code stops all associated system operations and waits for a heartbeat message from the system component that is not communicating. 	Automatically clears after communication is re-established with applicable system component (device).
125	Critical	S30, furnace, air handler, outdoor unit, equipment interface or IHarmony damper control module	There is a hardware problem on a system component control.	<ul style="list-style-type: none"> ▶ There is a control hardware problem. ▶ Replace the control if the problem prevents operation and is persistent. ▶ Damper control module will remain in non-zone mode (all dampers open) for five minutes after priority condition no longer exist. 	Automatically clears 300 seconds after the issue no longer exists.
126	Critical	Furnace air handler or outdoor unit	There is an internal communication problem with a system component.	<ul style="list-style-type: none"> ▶ There is an internal hardware problem on the system component control. ▶ Typically the system component control will reset itself. ▶ Replace the system component (device) control if the problem prevents operation and is persistent. 	Automatically clears 300 seconds after the issue no longer exists.
130	Moderate	Equipment interface module	Air handler jumper is missing.	<ul style="list-style-type: none"> ▶ Configuration jumper missing on equipment interface module. NOTE: This is applicable in non-communicating applications only). ▶ Install the missing jumper. 	Automatically clears after the missing or incorrectly installed jumper is installed or corrected.
131	Critical	S30, furnace, air handler, outdoor unit, equipment interface or IHarmony damper control module	System component control parameters are corrupted.	<ul style="list-style-type: none"> ▶ Reconfigure the system. ▶ Replace the system component control if heating or cooling is not available. 	Will automatically clear when system component (device) passes memory self-test or system component control is replaced.
132	Critical	Air handler, equipment interface module or IHarmony damper control module	System component control software is corrupted.	<ul style="list-style-type: none"> ▶ Recycle power. ▶ If failure re-occurs, replace the system component control. 	Manual system power reset is required to recover from this alert code.
180	Critical	Furnace, air handler or equipment interface module	The thermostat has found a problem with a system component's outdoor temperature sensor.	<ul style="list-style-type: none"> ▶ In normal operation after system component control recognizes sensors, the alarm will be sent if valid temperature reading is lost. ▶ Compare outdoor sensor resistance to temperature / resistance charts in unit installation instructions. ▶ Replace sensor pack if necessary. ▶ At the beginning of (any) configuration, furnace, air-handler control or equipment interface module will detect the presence of the sensor(s). ▶ If detected (reading in range), appropriate feature will be set as 'installed' and shown in the 'About' screen. 	Automatically clears upon configuration, or sensing normal values.

Table 1. Alert Codes and Troubleshooting				Critical alerts are displayed on the Home screen, in the Homeowner alert button, and in the Installer alert button. Minor and moderate alerts are found only in the Installer alert button.	
Alert Code	Priority Condition	Applicable System Components	Alert Text	Component or System Operational State and Troubleshooting Tip	How to clear alert code
200	Critical	Furnace	The furnace roll out limit switch is open.	<ul style="list-style-type: none"> ▶ Correct the cause of roll out trip. ▶ Reset roll out switch. ▶ Test the furnace operation. 	Automatically clears after the furnace roll out switch is closed.
201	Critical	Furnace or air handler	The system has lost communication with the indoor unit's blower motor.	<ul style="list-style-type: none"> ▶ Lost communication with indoor blower motor. ▶ Possible causes include power outage, brown-out, motor not powered, loose wiring, condensation on system component control without cover on breaker. ▶ Problem may be on system component control or motor side. 	Automatically clears after communication is restored.
202	Critical	Furnace or air handler	The unit size code for the indoor unit and the size of blower motor do not match.	<ul style="list-style-type: none"> ▶ Incorrect appliance unit size code selected. ▶ Check for proper configuring under unit size codes for furnace/air handler in configuration guide or in installation instructions. ▶ Remove the thermostat from the system while applying power and reprogramming. 	Automatically clears after the correct match is detected following a reset.
203	Critical	Furnace or air handler	The unit size code for the indoor unit has not been selected.	<ul style="list-style-type: none"> ▶ No system component unit size code selected. ▶ Check for correct configuration. Unit size codes for furnace and air handler are listed in the system component configuration guide or installation instruction. ▶ Remove the thermostat from the system while applying power and reprogramming. 	Automatically clears after the correct match is detected following a reset.
204	Critical	Furnace	There is an issue with the furnace gas valve.	<ul style="list-style-type: none"> ▶ Check gas valve operation and wiring. 	Automatically clears after the issue is corrected.
205	Critical	Furnace	The furnace gas valve relay contact is closed.	<ul style="list-style-type: none"> ▶ Check wiring on control and gas valve. 	Automatically clears after the issue is corrected.
206	Critical	Furnace	The furnace gas valve second-stage relay is faulty.	<ul style="list-style-type: none"> ▶ Furnace will operate on first-stage for the remainder of the heating demand ▶ If unable to operate second-stage, replace furnace control. 	Automatically clears after the issue is corrected.
207	Critical	Furnace	The furnace hot surface igniter is open.	<ul style="list-style-type: none"> ▶ Measure the resistance of hot surface igniter. ▶ Replace the igniter if it is not within the specified range found in furnace installation instruction. 	Automatically clears after the issue is corrected.
223	Critical	Furnace	The furnace low pressure switch is open.	<ul style="list-style-type: none"> ▶ Check pressure (inches w. c.) of the low pressure switch closing during a heat call. ▶ Measure operating pressure (inches w. c.). ▶ Inspect vent and combustion air inducer for correct operation and restriction. ▶ Check for blocked CEHB or condensate drain and cracked hoses. 	Automatically clears after the issue is corrected.
224	Critical	Furnace	The furnace low pressure switch is stuck closed.	<ul style="list-style-type: none"> ▶ Check operation of low pressure switch to see if it is stuck closed for longer than 150 seconds during a heat call. ▶ Measure operating pressure (inches w. c.). ▶ Inspect vent and combustion air inducer for correct operation and restriction. 	Automatically clears after the issue is corrected.
225	Critical	Furnace	The furnace high pressure switch is failing to close.	<ul style="list-style-type: none"> ▶ Check pressure (inches w. c.) of high pressure switch closing during a heat call. ▶ Measure operating pressure (inches w. c.). ▶ Inspect vent and combustion air inducer for correct operation and restriction. ▶ Check for blocked CEHB or condensate drain and cracked hoses. 	Automatically clears after the issue is corrected.

Table 1. Alert Codes and Troubleshooting				Critical alerts are displayed on the Home screen, in the Homeowner alert button, and in the Installer alert button. Minor and moderate alerts are found only in the Installer alert button.	
Alert Code	Priority Condition	Applicable System Components	Alert Text	Component or System Operational State and Troubleshooting Tip	How to clear alert code
226	Critical	Furnace	The furnace high pressure switch is stuck closed.	<ul style="list-style-type: none"> ▶ Check operation of high pressure switch closing during a heat call. ▶ Measure operating pressure (inches w. c.). ▶ Inspect vent and combustion air inducer for correct operation and restriction. 	Automatically clears after the issue is corrected.
227	Moderate	Furnace	The furnace low pressure switch is open in run mode.	<ul style="list-style-type: none"> ▶ Check pressure (inches w. c.) of low pressure switch closing during a heat call. ▶ Measure operating pressure (inches w.c.). ▶ Inspect vent and combustion air inducer for correct operation and restriction. ▶ Check for blocked CEHB or condensate drain and cracked hoses. 	Automatically clears after the issue is corrected.
228	Moderate	Furnace	The furnace control is not able to calibrate the pressure switch.	<ul style="list-style-type: none"> ▶ Unable to perform pressure switch calibration. ▶ Check vent system and pressure switch wiring connections. ▶ Check the drain trap for blockage. ▶ Check for blocked CEHB or condensate drain and cracked hoses. 	Automatically clears after a successful calibration.
229	Minor	Furnace	The furnace control has switched to high fire ignition because the low fire pressure switch did not close in the allowed time.	Furnace control switched to high fire ignition because low fire pressure switch did not close in allowed time.	No action is needed.
240	Moderate	Furnace	The furnace flame current is low.	<ul style="list-style-type: none"> ▶ Check micro-amperes of the flame sensor using thermostat diagnostics. ▶ Clean or replace the flame sensor. ▶ Measure voltage of neutral to ground to ensure good unit ground. ▶ Clean face of burner assembly. ▶ Check for AC voltage from flame sensor electrode to ground. 	Automatically clears after a proper micro-amp reading has been sensed.
241	Critical	Furnace	The furnace flame is going out while the furnace is heating.	<ul style="list-style-type: none"> ▶ Shut off gas. ▶ Check for a gas valve leak. ▶ Replace the gas valve if needed. ▶ Check for low flame signal. 	Automatically clears when a heat call ends successfully.
250	Moderate	Furnace and DCM	The furnace primary limit switch is open. NOTE: If limit switch is not closed within three minutes, the unit will go into a 60 minute soft lockout (WatchGuard mode)	<ul style="list-style-type: none"> ▶ Check for high gas pressure ▶ Low supply air due to plugged or restriction in system (example: dirty air filter or blockage in duct work) ▶ Limit trips will place the iHarmony® zoning system into non-zone mode. ▶ Check for proper air flow. ▶ Check for non-functioning zone dampers. <p>NOTE: Refer to S&A Note ACC-14-01 - iHarmony® and SLP98 - Insufficient Zone Heating and Alarm Code 250 Issues for corrective actions.</p>	Automatically clears when a heat call ends successfully. NOTE: If this issue occurred on an iHarmony® zoning system, the field will need to manually activate the zoning.
252	Moderate	Furnace	The furnace discharge air-temperature is high.	<ul style="list-style-type: none"> ▶ Check temperature rise, air flow and input rate. ▶ Check for dirty air filter(s). 	Automatically clears when a heat call ends successfully.

Table 1. Alert Codes and Troubleshooting				Critical alerts are displayed on the Home screen, in the Homeowner alert button, and in the Installer alert button. Minor and moderate alerts are found only in the Installer alert button.	
Alert Code	Priority Condition	Applicable System Components	Alert Text	Component or System Operational State and Troubleshooting Tip	How to clear alert code
270	Critical	Furnace	The furnace is in WatchGuard mode. The furnace igniter cannot turn on the flame.	<ul style="list-style-type: none"> ▶ This is a five strike condition during a single demand. ▶ Check for proper gas flow. ▶ Ensure that igniter is lighting burner. ▶ Check flame sensor current. ▶ Check for dirty filters. ▶ Check for blocked CEHB or condensate drain and cracked hoses. 	Automatically clears on successful ignition.
271	Critical	Furnace	The furnace is in WatchGuard mode. The furnace low pressure switch is open.	<ul style="list-style-type: none"> ▶ This is a five strike condition during a single demand. ▶ Check pressure (inches w. c.) of low pressure switch closing during a heat call. ▶ Measure operating pressure (inches w. c.). ▶ Inspect vent and combustion air inducer for correct operation and restriction. 	Automatically clears on successful ignition.
272	Critical	Furnace	The furnace low pressure switch is open during run mode.	<ul style="list-style-type: none"> ▶ The system will go into WatchGuard mode. ▶ Check operation of low pressure switch to see if it is stuck open during a heat call. ▶ Measure operating pressure (inches w. c.). ▶ Inspect vent and combustion air inducer for correct operation and restriction. ▶ Check for blocked CEHB or condensate drain and cracked hoses. 	Automatically clears when a heat call ends successfully.
273	Critical	Furnace	The furnace flame is going off during a heating cycle.	<ul style="list-style-type: none"> ▶ The system will go into WatchGuard mode. ▶ Check micro-amperes of flame sensor using thermostat diagnostics. ▶ Clean or replace sensor. ▶ Measure voltage of neutral to ground to ensure good unit ground. ▶ Clean face of burner assembly. 	Automatically clears when a heat call ends successfully.
274	Critical	Furnace	The furnace limit switch has been open for more than three minutes.	<ul style="list-style-type: none"> ▶ The system will go into WatchGuard mode. ▶ Check firing rate and air flow. ▶ Check for air blockage. 	Automatically clears when a heat call ends successfully.
275	Critical	Furnace	The furnace flame is out of sequence.	<ul style="list-style-type: none"> ▶ The system will go into WatchGuard mode. ▶ Shut off gas. ▶ Check for gas valve leak. 	Automatically clears on successful ignition.
276	Critical	Furnace	The furnace is not able to calibrate or the high pressure switch opened or failed to close in run mode.	<ul style="list-style-type: none"> ▶ The system will go into WatchGuard mode. ▶ Check vent system and pressure switch wiring connections. 	Automatically clears when the furnace calibrates itself successfully.
290	Critical	Furnace	There is a problem with the furnace ignition circuit.	<ul style="list-style-type: none"> ▶ The system will go into WatchGuard mode. ▶ Measure resistance of hot surface igniter. ▶ Replace the hot surface igniter if it is not within specifications. ▶ Measure voltage to igniter. 	Automatically clears on successful ignition

Table 1. Alert Codes and Troubleshooting				Critical alerts are displayed on the Home screen, in the Homeowner alert button, and in the Installer alert button. Minor and moderate alerts are found only in the Installer alert button.	
Alert Code	Priority Condition	Applicable System Components	Alert Text	Component or System Operational State and Troubleshooting Tip	How to clear alert code
291	Critical	Furnace	The heating airflow is below the minimum required level.	<ul style="list-style-type: none"> ▶ The system will go into WatchGuard mode. ▶ Check for dirty air filter(s) and other air flow restrictions. ▶ Check blower performance. 	Automatically clears when a heat call ends successfully.
292	Critical	Furnace or air handler	The indoor unit blower motor will not start.	<ul style="list-style-type: none"> ▶ The system will go into WatchGuard mode. ▶ Indoor blower motor unable to start. ▶ This could be due to seized bearing, stuck wheel, and obstructions. ▶ Replace motor, motor module or wheel if assembly does not operate or meet performance standards. 	Automatically clears after the indoor blower motor starts successfully.
294	Critical	Furnace	There is over current in the furnace inducer motor.	<ul style="list-style-type: none"> ▶ The system will go into WatchGuard mode. ▶ Check combustion blower bearings, wiring and amps. ▶ Replace furnace inducer motor if it does not operate or does not meet performance standards. 	Automatically clears after inducer motor current is sensed to be in-range after the ignition following either WatchGuard mode or unit reset.
295	Minor	Furnace	The indoor blower motor is overheating.	<ul style="list-style-type: none"> ▶ Indoor blower motor over temperature (motor tripped on internal protector). ▶ Check motor bearings and amps. ▶ Replace indoor blower motor if necessary. ▶ Check for high duct static. 	Automatically clears after blower demand is satisfied.
310	Critical	Furnace, air handler equipment interface module or damper control module	There is a problem with system component's discharge air sensor.	<ul style="list-style-type: none"> ▶ Compare outdoor sensor resistance to temperature / resistance charts in system component installation instruction. ▶ Replace discharge air sensor if necessary. ▶ Damper control module will operate in non-zone mode (all dampers open). 	Automatically clears 30 seconds after fault is detected as recovered.
311	Minor	Furnace	The heat firing rate has been reduced to match available airflow (cutback mode).	<ul style="list-style-type: none"> ▶ This is a Warning Only alert code. ▶ Furnace blower in cutback mode due to restricted airflow. ▶ Reduce firing rate every 60 seconds to match available CFM. ▶ Check air filter and duct system. ▶ To clear, replace air filter if needed or repair or add additional ducting. ▶ Two-stage controls will reduce firing rate to first stage. 	Automatically clears when a heat call finishes successfully.
312	Minor	Furnace or air handler	The indoor blower cannot provide the requested CFM due to high static pressure.	<ul style="list-style-type: none"> ▶ This is a Warning Only alert code. ▶ Possible restricted airflow - Indoor blower is running at a reduced CFM (Cutback Mode). ▶ The variable speed motor has pre-set speed and torque limiters to protect the motor from damage caused by operating outside of design parameters (0 to 0.8" e.g. total external static pressure). ▶ Check air filter and duct system. ▶ To clear, replace air filter if needed or repair or add additional ducting. 	Automatically clears after the current service demand is satisfied.

Table 1. Alert Codes and Troubleshooting				Critical alerts are displayed on the Home screen, in the Homeowner alert button, and in the Installer alert button. Minor and moderate alerts are found only in the Installer alert button.	
Alert Code	Priority Condition	Applicable System Components	Alert Text	Component or System Operational State and Troubleshooting Tip	How to clear alert code
313	Minor	Furnace, air handler and outdoor unit	The indoor and outdoor unit capacities do not match.	<ul style="list-style-type: none"> ▶ This is a Warning Only alert code. ▶ Check for proper system component configuring in installation instructions. ▶ The system will operate, but might not meet efficiency and capacity parameters. 	Automatically clears after commissioning is complete.
330	Critical		Link relay problem	▶	
331			RSBus communication link problem	▶	
344	Critical	Furnace	Relay Y1 Failure	<ul style="list-style-type: none"> ▶ Possible Y1 relay failure. ▶ All system operations will stop. 	Automatically clears 300 seconds after Y1 input sensed OFF.
345	Critical	Air handler, equipment interface module or heat pump	The O relay on the system component has failed. Either the pilot relay contacts did not close or the relay coil did not energize.	<ul style="list-style-type: none"> ▶ Possible O relay / stage 1 failure. ▶ Pilot relay contacts did not close or the relay coil did not energize. ▶ Replace system component (device) control. ▶ If error is applicable to the XC/XP 25, the outdoor control will need to be replaced. 	Automatically clears after the fault recovered following reset.
346	Critical	Air handler	The heat pump configuration link not cut on the air handler control.	<ul style="list-style-type: none"> ▶ Configuration link not cut on air handler control. ▶ Cut O to R. ▶ This is only applicable with non-communicating heat pump with communicating indoor unit. 	Automatically clears when the system detects that the issue no longer exists.
347	Critical	Furnace, air handler or equipment interface module	The Y1 relay on the applicable system component has failed. Either the pilot relay contacts did not close or the relay coil did not energize.	<ul style="list-style-type: none"> ▶ System operation will stop. ▶ Possible Y1 relay / stage 1 failure. ▶ Pilot relay contacts did not close or the relay coil did not energize; ▶ There is no input back to the applicable system component control. 	Automatically clears after reset and Y1 input sensed.
348	Critical	Furnace or air handler	The Y2 relay on the applicable system component has failed. Either the pilot relay contacts did not close or the relay coil did not energize.	<ul style="list-style-type: none"> ▶ Possible Y2 relay / stage 2 failure. ▶ Furnace pilot relay contacts did not close or the relay coil did not energize ▶ No input back to furnace or air handler control. . 	Automatically clears when the system detects that the issue no longer exists.
349	Critical	Furnace	The O to R link on the furnace needs to be restored.	<ul style="list-style-type: none"> ▶ Configuration link R to O needs to be restored. ▶ Repair cut link by hard-wiring the R to O terminals on the terminal strip. ▶ Only applicable in non-communicating mode. 	Automatically clears when the system detects that the issue no longer exists.
350	Critical	Air handler	The air-handler's electric heat is not configured or incorrectly configured.	<ul style="list-style-type: none"> ▶ Heat call with no configured or incorrectly configured electric heat. ▶ Check for proper configuring under Configuring Electric Heat Stages in the air handler installation instructions. IComfort MUST be removed from the system before configuring electric heat. 	Automatically clears after electrical heat detection is successful.
351	Critical	Air handler	There is an issue with the air-handler's first stage electric heat.	<ul style="list-style-type: none"> ▶ Either the pilot relay contacts did not close or the relay coil in the electric heat section did not energize. ▶ Possible heat section / stage 1 failure. ▶ Pilot relay contacts did not close, or the relay coil in the electric heat section did not energize. ▶ Air handler will operate on HP first stage for reminder of the heat call. 	Automatically clears after fault recovered.

Table 1. Alert Codes and Troubleshooting				Critical alerts are displayed on the Home screen, in the Homeowner alert button, and in the Installer alert button. Minor and moderate alerts are found only in the Installer alert button.	
Alert Code	Priority Condition	Applicable System Components	Alert Text	Component or System Operational State and Troubleshooting Tip	How to clear alert code
352	Critical	Air handler	There is a problem with the air-handler's second stage electric heat.	<ul style="list-style-type: none"> ▶ Either the pilot relay contacts did not close or the relay coil in the electric heat section did not energize. ▶ The air-handler will operate on first stage electric heat until the issue is resolved. 	Automatically clears after fault recovered.
353	Critical	Air handler	There is a problem with the air-handler's third stage electric heat.	<ul style="list-style-type: none"> ▶ Either the pilot relay contacts did not close or the relay coil in the electric heat section did not energize. ▶ The air-handler will operate on first stage electric heat until the issue is resolved. 	Automatically clears after fault recovered.
354	Critical	Air handler	There is a problem with the air-handler's fourth stage electric heat.	<ul style="list-style-type: none"> ▶ Either the pilot relay contacts did not close or the relay coil in the electric heat section did not energize. ▶ The air-handler will operate on first stage electric heat until the issue is resolved. 	Automatically clears after fault recovered.
355	Critical	Air handler	There is an issue with the air-handler's fifth stage electric heat.	<ul style="list-style-type: none"> ▶ Either the pilot relay contacts did not close or the relay coil in the electric heat section did not energize. ▶ The air-handler will operate on first stage electric heat until the issue is resolved. 	Automatically clears after fault recovered.
370	Critical	Furnace	The furnace control has not received 24VAC power for two minutes or more on the DS terminal	<ul style="list-style-type: none"> ▶ The system will not operate. ▶ Dealer has cut the W914 jumper (Dehum, Harmony III) ▶ The thermostat monitors the DS terminal in the furnace for power and if the link has been cut then power will be lost to DS. 	This alert code will clear when 24VAC is continuously sensed on DS terminal for a minimum of 10 seconds or on a power reset.
380	Moderate / Critical	Equipment interface module	Interlock relay failure (IFC or AHC mode only).	<ul style="list-style-type: none"> ▶ Interlock relay is energized, but input is not sensed after three seconds. ▶ There will be no heating or cooling due to this alert code – moderate condition. ▶ De-energize interlock relay and energize after five minutes if demand is still present – critical condition. 	Automatically clears after fault recovered.
381	Moderate / Critical	Equipment interface module	Interlock relay stuck (IFC or AHC modes only)	<ul style="list-style-type: none"> ▶ Interlock relay continuously sensed (with relay off). ▶ There is no heating and cooling operation – moderation condition. ▶ After 10 minutes if event still exist it will be escalated – critical condition. 	Automatically clears 30 seconds after fault clears.
382	Moderate	Equipment interface module	Relay W1 failure (IFC and AHC modes only)	<ul style="list-style-type: none"> ▶ W1 relay is energized but input is not sensed after three seconds. 	Automatically clears when W1 relay input is sensed.
400	Critical	Outdoor unit	The compressor internal overload has tripped.	<ul style="list-style-type: none"> ▶ Thermostat demand Y1 is present; however compressor is not running. ▶ Check power to unit. ▶ This alert code is automatically cleared after current is sensed in both RUN and START sensors for at least two seconds or after service is removed, or after power reset. 	Automatically clears when the system detects that the issue no longer exists.

Table 1. Alert Codes and Troubleshooting				Critical alerts are displayed on the Home screen, in the Homeowner alert button, and in the Installer alert button. Minor and moderate alerts are found only in the Installer alert button.	
Alert Code	Priority Condition	Applicable System Components	Alert Text	Component or System Operational State and Troubleshooting Tip	How to clear alert code
401	Moderate	Outdoor unit	Either the compressor ran for more than 18 hours continuously trying to cool the home during a single demand or the refrigerant pressure in the system is low.	<ul style="list-style-type: none"> ▶ Alert code will not lockout system. ▶ If the two-stage outdoor unit has: ▶ An outdoor control with blinking LED lights then the unit will run in low speed; ▶ An outdoor control with a 7-segment display, the outdoor control will display alert code 401, but continue to run in high speed. ▶ If the outdoor unit is a heat pump, and the outdoor temperature is less than 65°F, alert code 401 is ignored. ▶ Also monitors low pressure switch trips. 	Automatically clears after 30 consecutive normal run cycles or power reset.
402	Critical	Outdoor unit	Either the discharge or suction pressure level is out-of-limits, or the compressor has overloaded.	<ul style="list-style-type: none"> ▶ Check discharge or suction pressure. 	Automatically clears after four consecutive normal compressor run cycles.
403	Moderate	Outdoor unit	The compressor ran for less than three minutes to satisfy a thermostat demand.		Automatically clears after four consecutive normal compressor run cycles.
404	Critical	Outdoor unit	The compressor rotor is locked up.	<ul style="list-style-type: none"> ▶ Compressor rotor locked up due to run capacitor short, ▶ Bearings are seized ▶ Excessive liquid refrigerant, etc. (NOTE: May need to install hard start kit). 	Automatically clears after four consecutive normal run cycles or after power reset.
405	Critical	Outdoor Unit	The compressor circuit is open.	<ul style="list-style-type: none"> ▶ Compressor circuit open (due to power disconnection - open fuse, etc.) 	Automatically clears after one normal compressor run cycle.
406	Critical	Outdoor unit	The required amount of current is not passing through the START current transformer.		Automatically clears after current is sensed in START sensor, or after power reset.
407	Critical	Outdoor unit	The required amount of current is not passing through RUN current transformer.		Automatically clears after current is sensed in RUN sensor, one normal compressor run cycle, or after power reset
408	Critical	Outdoor unit	The compressor is running continuously.		Automatically clears one normal compressor run cycle or after power reset.
409	Moderate	Furnace, air handler or outdoor unit	The secondary voltage for the applicable system component has fallen below 18VAC.	<ul style="list-style-type: none"> ▶ Secondary voltage is below 18VAC. ▶ If this continues for 10 minutes, the thermostat will turn off the applicable system component. 	Automatically clears after voltage is detected as higher than 20VAC for two seconds or after power reset.
410	Moderate	Outdoor unit	Unit low pressure is below the required limit.	<ul style="list-style-type: none"> ▶ Check operating pressures. ▶ Low pressure switch opens at 40 psig (system shuts down) and closes at 90 psig (system restarts). 	Automatically clears when the system detects that the issue no longer exists.
411	Critical	Outdoor unit	The low pressure switch has opened five times during one cooling demand.	<ul style="list-style-type: none"> ▶ Thermostat will shut down the outdoor unit. ▶ Open low pressure switch error count reached five strikes. ▶ Check system charge using approach and sub cooling temperatures. ▶ Reset by putting outdoor unit control in test mode or resetting low voltage power. 	Automatically clears when the system detects that the issue no longer exists.

Critical alerts are displayed on the Home screen, in the Homeowner alert button, and in the Installer alert button. Minor and moderate alerts are found only in the Installer alert button.

Table 1. Alert Codes and Troubleshooting

Alert Code	Priority Condition	Applicable System Components	Alert Text	Component or System Operational State and Troubleshooting Tip	How to clear alert code
412	Moderate	Outdoor unit	The unit high pressure is above the required limit.	<ul style="list-style-type: none"> ▶ System is shut down ▶ Unit high pressure is above the upper limit. ▶ The high pressure switch for HFC-410A will open at 590PSIG and close at 418PSIG. ▶ Confirm that the system is properly charged with refrigerant. ▶ Check condenser fan motor, TXV, indoor unit blower motor, stuck reversing valve or clogged refrigerant filter. ▶ Confirm that the outdoor unit is clean. 	Automatically clears after the high pressure switch closes or a power reset
413	Critical	Outdoor unit	The high pressure switch has opened five times during one cooling demand.	<ul style="list-style-type: none"> ▶ Thermostat will shut down the outdoor unit. ▶ Open high pressure switch error count reached five strikes. ▶ Check system charge using superheat and sub-cooling temperatures. ▶ Check outdoor fan operation. ▶ Check for dirt or debris blocking air flow to outdoor unit. ▶ Reset by putting outdoor unit control in test mode or resetting low voltage power. 	Automatically clears when the system detects that the issue no longer exists.
414	Critical	Outdoor unit	The discharge line temperature is higher than the recommended upper limit of 279°F.	<ul style="list-style-type: none"> ▶ Discharge line temperature is greater than 279°F. ▶ Make sure coil is clean and airflow unobstructed in and out of condenser. ▶ Check system operating pressures and compare to unit charging charts in installation manual. 	Automatically clears after discharge temperature is less than 225°F.
415	Critical	Outdoor unit	The discharge line temperature has been consistently higher than the recommended upper limit of 279°F.	<ul style="list-style-type: none"> ▶ Discharge line high temperature error count reached five strikes during a single demand. ▶ Make sure coil is clean and airflow unobstructed in and out of condenser. ▶ Check system charge using superheat and sub cooling temperatures. ▶ Reset by putting outdoor control in test mode or resetting low voltage power. 	Automatically clears when the system detects that the issue no longer exists.
416	Critical	Outdoor unit	The outdoor coil sensor is either open, short-circuited or the temperature is out of sensor range.	<ul style="list-style-type: none"> ▶ Outdoor unit control will not perform demand or time / temperature defrost operation. (System will still heat or cool.) ▶ Sensor being detected open or shorted or temperature is out of sensor range. 	Automatically clears when outdoor unit control detects proper sensor readings.

Critical alerts are displayed on the Home screen, in the Homeowner alert button, and in the Installer alert button. Minor and moderate alerts are found only in the Installer alert button.

Table 1. Alert Codes and Troubleshooting

Alert Code	Priority Condition	Applicable System Components	Alert Text	Component or System Operational State and Troubleshooting Tip	How to clear alert code
417	Critical	Outdoor unit	The outdoor unit discharge sensor is either open, short-circuited or the temperature is out of sensor range.	<ul style="list-style-type: none"> ▶ Outdoor unit control will not perform demand or time / temperature defrost operation. (System will still heat or cool.) ▶ Outdoor unit control detects open or shorted sensor, or temperature that is out of sensor range. ▶ Critical alert after 10 minutes. ▶ Reset by replacing sensor. ▶ This fault is detected by allowing the unit to run for 90 seconds before checking sensor resistance. ▶ If the sensor resistance is not within range after 90 seconds, the board will count one fault. ▶ After five faults, the outdoor control will lock out. ▶ Check for proper sensor reading and attachment to line. ▶ Replace outdoor control or sensor if out-of-specifications. 	Automatically clears when the system detects that the issue no longer exists.
417	Moderate / Critical	Harmony Damper control module	The damper control discharge air temperature sensor is either open, short-circuited or the temperature is out of sensor range.	<ul style="list-style-type: none"> ▶ Outdoor control will not perform any defrost tempering – moderate condition. ▶ The damper control module detects open or shorted discharge sensor, or temperature that is out of discharge sensor range. ▶ Check the resistance of the discharge sensor and compare to temperature resistance chart - replace if needed. ▶ Reset by replacing the discharge sensor. ▶ This fault is detected by allowing the unit to run for 90 seconds before checking discharge sensor resistance. ▶ If the discharge sensor resistance is not within range after 90 seconds, the control will count one fault. ▶ After five faults, the control will lock out – critical condition. ▶ Check for proper sensor reading and attachment to line. 	Automatically clears after a power reset.
418	Moderate	Equipment interface module and outdoor unit	There is a faulty W output circuit.	<ul style="list-style-type: none"> ▶ W terminal is energized <u>while in cooling mode</u>. ▶ Possible cause may be a stuck closed relay on the control, or something external to the control that is energizing W terminal when it should not be energized. ▶ Disconnect any wiring from the W terminal. ▶ If 24VAC is still on the terminal, then it is a stuck relay. ▶ If 24VAC disappears, then there is a need to check any of the wires hooked up to the W terminal. 	Automatically clears after fault signal is removed.
419	Critical	Equipment interface module and outdoor unit	The W output has reported more than five errors.	<ul style="list-style-type: none"> ▶ The system will shut down the outdoor unit. ▶ The W output (code E418) on the outdoor unit has reported more than five strikes. ▶ Disconnect thermostat wire from W and verify there is no 24VAC on the W. ▶ If 24VAC is present, replace the outdoor control. 	Automatically clears after power recycled.

Table 1. Alert Codes and Troubleshooting				Critical alerts are displayed on the Home screen, in the Homeowner alert button, and in the Installer alert button. Minor and moderate alerts are found only in the Installer alert button.	
Alert Code	Priority Condition	Applicable System Components	Alert Text	Component or System Operational State and Troubleshooting Tip	How to clear alert code
420	Critical	Air handler or equipment interface module	The heat pump defrost cycle has taken more than 20 minutes to complete.	<ul style="list-style-type: none"> ▶ Defrost cycle lasts longer than 20 minutes. ▶ Check heat pump operation. ▶ This is applicable only in communicating indoor unit with non-communicating heat pump. 	Automatically clears when W1 signal is removed.
421	Critical	Equipment interface module and outdoor unit	The W output terminal on the outdoor unit is not wired correctly.	<ul style="list-style-type: none"> ▶ Voltage sensed on W output terminal when Y1 out is deactivated. 	Automatically clears once voltage is not sense on output for power cycled.
422	Moderate	Outdoor unit	Compressor top cap switch exceeding thermal limit.	<ul style="list-style-type: none"> ▶ Check condenser fan motor, TXV and indoor unit blower motor. ▶ Check for stuck reversing valve or clogged refrigerant filter. ▶ XC/XP25: Check to ensure that one of the wires from the top cap switch has not been disconnected from one of the TP terminals on the outdoor control. Reconnect wire if disconnected. ▶ Check superheat and sub-cooling. 	Automatically clears when error is corrected.
423	Moderate / Critical	Outdoor unit	The inverter has detected a circuit issue.	<ul style="list-style-type: none"> ▶ When this condition is detected the outdoor control will stop outdoor unit operations and start the anti-short cycle timer – moderate condition. ▶ Outdoor control will lockout unit after 10 strikes within an hour – critical condition. 	A moderate alarm will clear automatically when the inverter detects the condition no longer exist and will send a clear alarm message. To clear critical alarm disconnect power to outdoor unit and restart.
424	Moderate	Outdoor unit	The liquid line temperature sensor has malfunctioned.	<ul style="list-style-type: none"> ▶ In normal operation after outdoor control recognizes sensors, the alert code will be sent if a valid temperature reading is lost. ▶ Compare liquid line sensor resistance to temperature / resistance charts in unit installation instructions. ▶ Replace sensor pack if necessary. ▶ At the beginning of (any) configuration, furnace or air handler control will detect the presence of the sensor(s). ▶ If detected (reading in range), appropriate feature will be set as 'installed' and shown in the iComfort Wi-Fi® thermostat 'About' screen. 	Automatically clears upon configuration, or sensing normal values.
425	Minor	Outdoor unit	Outdoor control has increased minimum compressor speed to allow for proper oil return due to low ambient temperature.	<ul style="list-style-type: none"> ▶ Outdoor ambient temperature is below system limit. ▶ Control will attempt to run at lowest allowed compressor speed to allow for proper oil return. 	Automatically clears when outdoor ambient temperature rises above limit for more than five minutes.
426	Critical	Outdoor unit	Excessive inverter alarms.	<ul style="list-style-type: none"> ▶ After ten faults within one hour outdoor control will lockout. ▶ Inverter alarms 12 to 14 and 53 do not count towards this lockout condition. 	To clear disconnect power to outdoor control and restart
427	Moderate / Critical	Outdoor unit	The inverter has detected a DC peak fault condition.	<ul style="list-style-type: none"> ▶ If condition (55A or higher) is detected, outdoor unit will stop (compressor and fan) – moderate condition. ▶ Anti-short cycle is initiated. ▶ If peak current (55A or higher) occurs 10 times within an hour, system will lockout – critical condition. 	To clear, disconnect and reconnect power to outdoor control.

Critical alerts are displayed on the Home screen, in the Homeowner alert button, and in the Installer alert button. Minor and moderate alerts are found only in the Installer alert button.

Table 1. Alert Codes and Troubleshooting

Alert Code	Priority Condition	Applicable System Components	Alert Text	Component or System Operational State and Troubleshooting Tip	How to clear alert code
428	Moderate / Critical	Outdoor unit	The inverter has detected a high main input current condition.	<ul style="list-style-type: none"> ▶ If condition is detected, outdoor unit will stop (compressor and fan) – moderate condition. ▶ Anti-short cycle is initiated. ▶ If condition occurs 10 times within an hour, system will lockout – critical condition. 	To clear, disconnect power to outdoor unit and restart.
429	Moderate / Critical	Outdoor unit	The inverter has detected a DC link low voltage condition.	<ul style="list-style-type: none"> ▶ On a call for compressor operation, if DC link power in inverter does not rise above 180 VDC for 2- and 3 -ton models, 250 VDC for 4- and 5-ton models within 30 seconds, the control will display a moderate code. ▶ If condition is detected, outdoor unit will stop (compressor and fan) – moderate condition. ▶ An anti-short cycle timer is initiated. If condition occurs 10 times within a 60 minute rolling time period, system will lock out and display alert code 429 – critical condition. ▶ The outdoor control anti-short cycle timer will time out and the unit will recycle the demand. ▶ Replace outdoor inverter. 	Automatically clears when the system detects that the issue no longer exists.
430	Moderate / Critical	Outdoor unit	Compressor start-up failure	<ul style="list-style-type: none"> ▶ If condition is detected, outdoor unit will stop (compressor and fan) – moderate condition. ▶ Anti-short cycle is initiated. ▶ If condition occurs 10 times within an hour, system will lockout – critical condition. 	To clear, disconnect power to outdoor unit and restart.
431	Moderate / Critical	Outdoor unit	The inverter has detected a PFC circuit over-current condition.	<ul style="list-style-type: none"> ▶ Error occurs when PFC detects an over current condition of 100A peak. ▶ If condition is detected, outdoor unit will stop (compressor and fan) – moderate condition. ▶ Anti-short cycle timer is initiated. ▶ If condition occurs 10 times within an hour, system will lockout – critical condition. 	To clear, disconnect power to outdoor unit and restart.
432	Moderate / Critical	Outdoor unit	The inverter has detected a DC link high voltage condition.	<ul style="list-style-type: none"> ▶ Error occurs when the DC link capacitor voltage is greater than 480VDC. ▶ If condition is detected, outdoor unit will stop (compressor and fan) – moderate condition. ▶ Anti-short cycle timer is initiated. ▶ If condition occurs 10 times within an hour, system will lockout – critical condition. 	To clear, disconnect power to outdoor unit and restart.
433	Moderate / Critical	Outdoor unit	Compressor phase current is too high.	<ul style="list-style-type: none"> ▶ Error occurs when compressor peak phase current is greater than 28A. ▶ Inverter will issue code 14 first and slow down to try to reduce the current. ▶ If the current remains high, outdoor unit will stop (compressor and fan) – moderate condition. ▶ Anti-short cycle timer is initiated. ▶ If condition occurs five times within an hour, system will lockout – critical condition. 	To clear alert code disconnect power to outdoor unit and restart.

Critical alerts are displayed on the Home screen, in the Homeowner alert button, and in the Installer alert button. Minor and moderate alerts are found only in the Installer alert button.

Table 1. Alert Codes and Troubleshooting

Alert Code	Priority Condition	Applicable System Components	Alert Text	Component or System Operational State and Troubleshooting Tip	How to clear alert code
434	Moderate / Critical	Outdoor unit	Outdoor control has lost communications with the inverter for greater than three minutes.	<ul style="list-style-type: none"> ▶ Outdoor control has lost communications with the inverter for greater than three minutes. ▶ Outdoor control will stop all compressor demands – moderate condition. ▶ Recycle power to the inverter by de-energizing the contactor for two minutes. ▶ If this occurs three times in one thermostat call, the outdoor unit will lock out and display alert code 434 – critical condition. ▶ Check for loose or disconnected electrical connections. ▶ Interruption of main power to inverter. 	Automatically clears when the system detects that the issue no longer exists.
435	Moderate / Critical	Outdoor unit	Inverter internal error.	<ul style="list-style-type: none"> ▶ When this error occurs, the outdoor control will cycle power to the inverter by opening the contactor for two minutes – moderate condition. ▶ Outdoor control will cycle power to the inverter three times and then outdoor unit is locked out – critical condition. 	To clear alert code disconnect power to outdoor unit and restart.
436	Moderate / Critical	Outdoor unit	Inverter heat sink temperature exceeded limit.	<ul style="list-style-type: none"> ▶ This occurs when the heat sink temperature exceeds the inverter limit. Inverter will issue inverter alert code 13 first and slow down to try to cool the heat sink. ▶ If temperature remains high, outdoor unit will stop both compressor and fan – moderate condition. ▶ Anti-short cycle is initiated. ▶ If condition occurs five times within an hour, system will lockout – critical condition. ▶ The screws that hold the inverter to the inverter board were loose causing poor contact between these two components. ▶ Tighten screws that hold the heat sink to the inverter control board. <p>NOTE: Wait five minutes for all capacitors to discharge before checking screws.</p>	<p>Moderate condition will automatically clear when the inverter sends an alarm clear message.</p> <p>Critical condition is cleared by disconnecting power to the outdoor unit and restart.</p>
437	Moderate / Critical	Outdoor unit	Heat sink temperature sensor fault has occurred (temperature less than 4 °F or greater than 264°F after 10 minutes of operation).	<ul style="list-style-type: none"> ▶ When the temperature sensor detects a temperature less than 0.4°F or greater than 264°F after 10 minutes of operation. ▶ Outdoor unit will stop both compressor and fan – moderate condition. ▶ Anti-short cycle is initiated. ▶ If condition occurs five times within an hour, system will lockout – critical condition. 	<p>Moderate priority condition will automatically clear when the inverter sends an alarm clear message.</p> <p>Critical priority condition can be cleared by disconnecting and re-connecting power to outdoor unit to restart.</p>
438	Moderate / Critical	Outdoor unit	The inverter has detected a PFC circuit over-current condition.	<ul style="list-style-type: none"> ▶ The inverter has detected a power factor correction (PFC) over current condition. This may be caused by a high load condition, high pressure, or outdoor fan failure. ▶ Outdoor control will display the code when the inverter has detected the error – moderate condition. ▶ After three minutes, the inverter will reset and the compressor will resume operation. ▶ If the error condition occurs 10 times within a 60 minute rolling time period, the outdoor unit control will lock out operation of the outdoor unit – critical condition. ▶ Possible issue is system running at high pressures. ▶ Check for high pressure trips or other alert codes in iComfort® S30 and outdoor control. 	<p>Moderate priority condition is automatically cleared when the inverter sends a clear message.</p> <p>Critical priority condition will automatically clear when inverter is power cycled.</p>

Critical alerts are displayed on the Home screen, in the Homeowner alert button, and in the Installer alert button. Minor and moderate alerts are found only in the Installer alert button.

Table 1. Alert Codes and Troubleshooting

Alert Code	Priority Condition	Applicable System Components	Alert Text	Component or System Operational State and Troubleshooting Tip	How to clear alert code
439	Moderate	Outdoor unit	Compressor slowdown due to high input current.	<ul style="list-style-type: none"> ▶ Input current is approaching a high limit. ▶ Compressor speed will automatically slow down. The outdoor control will continue sending the inverter speed demanded by the thermostat. ▶ The outdoor control will set indoor CFM and outdoor RPM to values according to demand percentage rather than the actual Hz. 	Automatically clears when the condition no longer exists.
440	Moderate	Outdoor unit	Compressor slowdown due to high heat sink temperature.	<ul style="list-style-type: none"> ▶ Heat sink temperature is approaching limit. ▶ The compressor speed automatically slows to reduce heat sink temperature. ▶ The control sets indoor CFM and outdoor RPM to values according to demand percentage rather than the actual Hz. ▶ Feedback from supplier tear down of inverter indicates that the screws that hold the inverter to the inverter board were loose causing poor contact between these two components. ▶ Tighten screws that hold the heat sink to the inverter control board. <p>NOTE: Wait five minutes for all capacitors to discharge before checking screws.</p>	Automatically clears when the condition no longer exists.
441	Moderate	Outdoor unit	Compressor slowdown due to high compressor current.	<ul style="list-style-type: none"> ▶ Compressor slowdown due to high compressor current. ▶ Compressor current is approaching limit. ▶ The compressor speed automatically slows. ▶ The control sets indoor CFM and outdoor RPM to values according to demand percentage rather than the actual Hz. ▶ Possible issue is system running at high pressures. ▶ Check for high pressure trips or other alert codes in iComfort® S30 and outdoor control. 	Automatically clears when the condition no longer exists.
442	Critical	Outdoor unit	The top cap switch has opened five times within one hour. As a result, the outdoor unit is locked out.	<ul style="list-style-type: none"> ▶ This condition occurs when compressor thermal protection sensor opens five times within one hour. ▶ Outdoor unit will stop. 	To clear, disconnect power to outdoor unit and restart.
443	Critical	Outdoor unit	Incorrect appliance unit size code selected.	<ul style="list-style-type: none"> ▶ Check for proper configuring under unit size code used for outdoor unit (see unit configuration guide or in installation instructions). ▶ If replacing inverter, verify inverter model matches unit size. ▶ Remove the thermostat from the system while applying power and reprogramming. 	Automatically clears after the correct match is detected following a power reset.
530	Moderate / Critical	IHarmony Damper control module	Low Damper 24VAC Voltage	<ul style="list-style-type: none"> ▶ Damper supply voltage is less than 18VAC. ▶ Maintain non-zone mode for five minutes after alarm clears. 	Automatically clears when the condition no longer exists.
532	Moderate	IHarmony Damper control module	Zoning Pressure Switch Opened (high pressure)	<ul style="list-style-type: none"> ▶ Compressor pressure is above the specified limit. ▶ Compressor is turned off. ▶ Zoning will be restored once the high pressure switch closes. 	Automatically clears after compressor pressure is within limits.

Table 1. Alert Codes and Troubleshooting				Critical alerts are displayed on the Home screen, in the Homeowner alert button, and in the Installer alert button. Minor and moderate alerts are found only in the Installer alert button.	
Alert Code	Priority Condition	Applicable System Components	Alert Text	Component or System Operational State and Troubleshooting Tip	How to clear alert code
542	Moderate/ Critical	IHarmony Damper control module	Zone 1 Temperature Sensor Problem	<ul style="list-style-type: none"> ▶ Zone temperature sensor reading out of range. ▶ Open or short zone temperature sensor detected for more than five second. ▶ Damper control module will operate in non-zone mode (all dampers open) – moderate condition. ▶ If after 10 minutes the condition does not change, the priority code is change to critical. System will continue to operate in non-zone mode. 	Automatically clears 30 seconds after condition no longer exist.
543	Moderate/ Critical	IHarmony Damper control module	Zone 2 Temperature Sensor Problem		
544	Moderate/ Critical	IHarmony Damper control module	Zone 3 Temperature Sensor Problem		
545	Moderate/ Critical	IHarmony Damper control module	Zone 4 Temperature Sensor Problem		
594	Moderate / Critical	Equipment interface module	Pre-coil discharge air temperature sensor problem (DFM mode only). Advances from moderate to critical after ten (10) minutes.	<ul style="list-style-type: none"> ▶ Interlock relay energized, but input not sensed after three seconds. ▶ No heating and cooling operations. ▶ De-energize interlock relay and re-energized five minutes later if demand is still present. 	Alarm clears five minutes after fault clears.
600	Critical	Outdoor unit	Compressor has been cycled OFF on utility load shedding.	<ul style="list-style-type: none"> ▶ Load shedding function provides a method for a local utility company to limit the maximum power level usage of the outdoor unit. ▶ The feature is activated by applying 24VAC power to the L and C terminals on the outdoor control. 	Automatically clears when L terminal is inactive.
601	Critical	Heat Pump	Outdoor unit has been cycled OFF on low temperature protection.	<ul style="list-style-type: none"> ▶ This is a low temperature protection feature. ▶ Outdoor unit will not operate when the outdoor temperature is at or below -4°F (-20°C). ▶ If the unit is operating and the outdoor temperature drops below -4°F (-20°C), the unit will continue to operate until the iComfort® S30 is satisfied or the outdoor temperature drops to -15°F (-26°C). ▶ Outdoor unit ambient sensor provides temperature readings. 	Automatically clears when priority condition no longer exists.
602	Minor	Air Conditioner	Low ambient conditions prevent the use of the air conditioner unit.	Outdoor unit will not operate due to outdoor ambient conditions.	Automatically clears when priority condition no longer exists.
700	Moderate	S30	The temperature sensor in the thermostat is not working properly.	<ul style="list-style-type: none"> ▶ Recalibrate thermostat to clear. ▶ Replace thermostat if needed. 	Automatically clears when the system detects that the issue no longer exists.
701	Moderate	S30	The thermostat is reading indoor temperatures above the pre-programmed limit.	<ul style="list-style-type: none"> ▶ Recalibrate thermostat to clear ▶ Cool thermostat ▶ Adjust set point. ▶ Replace thermostat, if needed. 	Automatically clears when the system detects that the issue no longer exists.
702	Moderate	S30	The thermostat is reading indoor temperatures below the pre-programmed limit.		
703	Moderate	S30	The humidity sensor in the thermostat is not working properly.		

Critical alerts are displayed on the Home screen, in the Homeowner alert button, and in the Installer alert button. Minor and moderate alerts are found only in the Installer alert button.

Table 1. Alert Codes and Troubleshooting

Alert Code	Priority Condition	Applicable System Components	Alert Text	Component or System Operational State and Troubleshooting Tip	How to clear alert code
704	Moderate	S30	The thermostat is reading indoor humidity levels above the pre-programmed limit.	<ul style="list-style-type: none"> ▶ Recalibrate thermostat to clear. ▶ Replace thermostat, if needed. 	Automatically clears when the system detects that the issue no longer exists.
705	Moderate	S30	The thermostat is reading indoor humidity levels below the pre-programmed limit.		
65537	Critical	S30 Mag-Lock Base	Missing base.	Base not detected for more than 30 seconds.	Automatically clears once is detected for two seconds.
65539	Critical	S30 HD Wall Display	Missing thermostat	Thermostat not detected for more than 30 seconds.	Automatically clears once is detected for two seconds.
65543	Info	S30	Firmware updated	When new firmware has been successfully updated to iComfort® S30.	Clears automatically after successfully update.
65544	Critical	S30	Too many siblings	The system is limited to no more than five (5) Smart Hubs in a local Wi-Fi network	Once the system detects that only five or less Smart Hubs are detected on the network will the alert code automatically clears.

MAINTENANCE HISTORY

This screen provides information on past maintenance performed on the system. Information can be sorted by last 24 hours, last 30 days , last 12 months and all. Additional maintenance tasks can be added using the **add manual** entry options located in the upper right portion of the screen. Details concerning each listed history can be displayed by pressing on the desired history.

TESTS

Verify Airflow Per Zone is the first screen to appear under this selection. If no zoning is installed, zone airflow settings will be for zone 1 only. If zoning equipment is detected by the system then zones 1 through 4 will be listed. These screens allow for verification and modification of CFMs for blower, heating and cooling circulation. Press **continue** to proceed to the next screen.

Select Test to Run is the next screen to appear. Depending on hardware present, various tests are available. By default all items to be tested are enabled. Selecting a specific test will un-check the item. When a specific set of tests are completed the results will be displayed on the screen next to the tested item. Press **continue** to proceed to the next set of test items. Once all tests are completed press **done** to return to the *select tests to run screen*. Press the **left arrow** at the top left side of screen to return to the Dealer Control Center.

DIAGNOSTICS

This screen allows the installer to test all major communicating components of the system indoor unit (air handler or furnace), outdoor unit (air conditioner or heat pump) and zoning control (if applicable). Pressing the stop diagnostics button will pause the diagnostic function.

Press the **left arrow** at the top left side of screen to return to the Dealer Control Center.

INFORMATION

DEALER INFORMATION

The dealer information screen will appear. The next screen will be for dealer information. Here either the dealer ID or phone number can be added. Once the system is connected to the Internet, the remaining information is automatically populated. Not all information for this screen will be viewable. Press and hold and then drag up to access the remaining information on the screen.

Information Required: Dealer ID and / or dealer phone number. Information that can be manually entered is name, email website, dealer address which includes address 1, address 2, city state and zip code. Once completed press **continue**.

IMPORTANT: ADDING DEALER INFORMATION WILL ENSURE THE ICOMFORT® S30 IS ASSOCIATED WITH YOUR DAVENET ACCOUNT WHEN CONNECTIONG TO THE LENNOX SERVER.

Warning Screen: If neither the dealer ID or phone number is provided, a warning screen will appear. The warning screen will provided information on the limitation imposed on the system if this information is missing. Press **no** to return to the above screen to complete the information requested or press **yes** to continue.

GENERAL INFORMATION

On this screen general information needs to be verified or changed. Press any item to change its contents. A pop-up screen will appear that will allow the information to be added or changed.

Information Required:

1. Select desired language (ENGLISH, FRANÇAIS, ESPAÑOL).
2. Select country / region.
3. Select time and date which includes time, date, time zone, daylight savings time (ON/OFF) and temperature unit (Fahrenheit or Celsius).

Once completed press **continue**.

HOME ADDRESS

On this screen general information needs to be verified or changed. Press any line item to change its contents. Information to be added is address 1, address 2, state, city and zip code.

Complete the requested information and press the continue button.

SYSTEM CONFIGURATIONS

COMPLETE ICOMFORT® SYSTEMS — FURNACE AND AIR CONDITIONER

An iComfort® gas furnace (G71MPP, EL296V, SLP98, SL280) with an iComfort® air conditioner (XC17, XC20, XC21 or XC25 only) unit.

1. **Wiring**—See **Communicating System and optional accessories Wiring** diagrams.
 - 4-conductor thermostat wire between the HD Display, Smart-Hub and gas furnace (R, i+, i-, C)
 - 4-conductor thermostat wire from the integrated furnace control (IFC) terminal strip to the iComfort® air conditioner unit (R, i+, i-, C)
 - Wiring as required for accessories
2. **DO NOT** cut any option links on furnace control.
3. After the entire system is wired, power up the system; the iComfort® S30 will check the system for installed communication devices.
4. During the **Installer System Setup** (see page 14) you will end that process with the **dealer control center**. From there select **equipment** to modified any system or equipment settings.

5. From the equipment list, press **Furnace**. From this furnace screen you will have access to the various airflow settings. Set the system air volumes according the needs of the home.
6. When all CFM settings are complete, press the **back** arrow (<) at the top left-hand of the screen to return to the **dealer control center**. Press **tests** to access the test section
7. Here you will have another opportunity to adjust blower circulation, heating and cooling circulation air flows. Use the plus or minus buttons to adjust up or down the CFM settings. Once adjustments are completed, press **continue**.
8. Under the **select test to run**, you may un-check any test not required, or run all test. Press **start tests** to proceed. Once each test section is completed, press continue to proceed to the next group of test.
9. Once all test are completed, press done. The will return you to the select tests to run screen. If finish, press the **back** arrow (<) at the top left-hand of the screen to return to the **dealer control center**. Press exit to return the HOME screen.

TIPS

An outdoor temperature sensor is provided in all iComfort® outdoor units. To display the outdoor temperature on the home screen of the HD Display, you can enable this feature under the dealer control center. Use the following procedure to enable the outdoor temperature sensor display.

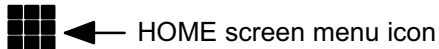

1. Press Menu and then **press settings**.
2. Press **advanced settings** and then press **view dealer control center**.
3. Press **equipment** and then press **thermostat**.
4. Press **Outdoor Temperature** and select **sensor**. Press the **back** arrow (<) at the top left-hand of the screen to return to the **dealer control center**.
5. Press **exit**
6. From the Home screen, press **menu** and then press **settings**.
7. Press **display** and press **outdoor temperature**.
8. Press **sensor** to select the **outdoor sensor**. Press < **display** to return to display screen. There under outdoor temperature it will indicate sensor.
9. Press the Home icon at the top left-hand corner of the screen to return to Home screen.

To enable the Indoor Humidity Display on the Home screen use the following procedure:

1. Press Menu and then **press settings**.
2. Press **advanced settings** and then press **view dealer control center**.
3. Press **equipment** and then press **thermostat**.
4. Press **Display Indoor Humidity** and toggle to on. Press the **back** arrow (<) at the top left-hand of the screen to return to the **dealer control center**.
5. Press **exit**
6. From the Home screen, press **menu** and then press **settings**.
7. Press **display** and go to **indoor humidity** and toggle to on.
8. Press the Home icon at the top left-hand corner of the screen to return to Home screen.

COMPLETE ICOMFORT® SYSTEMS — FURNACE AND HP UNIT (DUAL-FUEL)

Dual fuel system using an iComfort® gas furnace (G71MPP, EL296V, SLP98, SL280) with an iComfort® heat pump (XP17, XP17N, XP21, XP21N and XP25 only).

1. **Wiring**—See **Communicating System and optional accessories Wiring** diagrams.
 - 4-conductor thermostat wire between the HD Display, Smart-Hub and gas furnace (R, i+, i-, C)
 - 4-conductor thermostat wire from the furnace terminal strip to the iComfort® heat pump (R, i+, i-, C)
 - Wiring as required for accessories
2. **DO NOT** cut any option link on furnace control.
3. After the entire system is wired, power up the system; the iComfort® S30 will check the system for installed communication devices.
4. During the **Installer System Setup** (see page 14) you will end that process with the **dealer control center**. From there select **equipment** to modified any system or equipment settings.
5. Select Balance Point Control and press **edit**. Use the down arrow to select **Enabled**. A pop-up warning screen indicating that due to enabling Balance Point Control other related parameter values were automatically changed.

6. Complete **Balance Point Control** by editing the High and Low Balance Points. It is not necessary to change the defaults.
7. From the equipment list, press **Furnace**. From this furnace screen you will have access to the various airflow settings. Set the system air volumes according the needs of the home.
8. When all CFM settings are complete, press the **back** arrow (<) at the top left-hand of the screen to return to the **dealer control center**. Press **tests** to access the test section
9. Here you will have another opportunity to adjust blower circulation, heating and cooling circulation air flows. Use the plus or minus buttons to adjust up or down the CFM settings. Once adjustments are completed, press **continue**.
10. Under the **select test to run**, you may un-check any test not required, or run all test. Press **start tests** to proceed. Once each test section is completed, press continue to proceed to the next group of test.
11. Once all test are completed, press done. The will return you to the select tests to run screen. If finish, press the **back** arrow (<) at the top left-hand of the screen to return to the **dealer control center**. Press exit to return the HOME screen.

TIPS

An outdoor temperature sensor is provided in all iComfort® outdoor. To display the outdoor temperature on the home screen of the HD Display, you can enable this feature under the dealer control center. Use the following procedure to enable the outdoor temperature sensor display.



← HOME screen menu icon

1. Press the **Menu** icon on the Home screen and then **press settings**.
2. Press **advanced settings** and then press **view dealer control center**.
3. Press **equipment** and then press **thermostat**.
4. Press **Outdoor Temperature** and select **sensor**. Press the **back** arrow (<) at the top left-hand of the screen to return to the **dealer control center**.
5. Press **exit**
6. From the Home screen, press **menu** and then press **settings**.
7. Press **display** and press **outdoor temperature**.
8. Press **sensor** to select the **outdoor sensor**. Press < **display** to return to display screen. There under outdoor temperature it will indicate sensor.
9. Press the Home icon at the top left-hand corner of the screen to return to Home screen.

To enable the Indoor Humidity Display on the Home screen use the following procedure:

1. Press the **Menu** icon on the Home screen and then **press settings**.
2. Press **advanced settings** and then press **view dealer control center**.
3. Press **equipment** and then press **thermostat**.
4. Press **Display Indoor Humidity** and toggle to on. Press the **back** arrow (<) at the top left-hand of the screen to return to the **dealer control center**.
5. Press **exit**
6. From the Home screen, press **menu** and then press **settings**.
7. Press **display** and go to **indoor humidity** and toggle to on.
8. Press the Home icon at the top left-hand corner of the screen to return to Home screen.

Gas heat is provided to temper the air during defrost cycles.

COMPLETE ICOMFORT® SYSTEMS — AIR HANDLER AND AIR CONDITIONER

An iComfort® air handler (CBX32MV or CBX40UHV) with an iComfort® air conditioner (XC17, XC20, XC21 or XC25 only).

IMPORTANT! Be sure to configure the air handler control so that heat strips (if used) information will be detected by the iComfort® S30. This must be done prior to powering up the system and control system.

1. Configure air handler control (AHC) for auxiliary heat strips if used.
2. **Wiring**—See Communicating System and optional accessories Wiring diagrams.
 - 4-conductor thermostat wire between the HD Display, Smart-Hub and air handler (R, i+, i-, C)
 - 4-conductor thermostat wire from the air handler terminal strip to the iComfort® air conditioner (R, i+, i-, C)
 - Wiring as required for accessories
3. **DO NOT** cut any option link on air handler control.
4. After the entire system is wired, power up the system; the iComfort® S30 will check the system for installed communication devices.

5. During the **Installer System Setup** (see page 14) you will end that process with the **dealer control center**. From there select **equipment** to modified any system or equipment settings.
6. From the equipment list, press **air handler**. From this air handler screen you will have access to the various airflow settings. Set the system air volumes according the needs of the home.
7. When all CFM settings are complete, press the **back** arrow (<) at the top left-hand of the screen to return to the **dealer control center**. Press **tests** to access the test section
8. Here you will have another opportunity to adjust blower circulation, heating and cooling circulation air flows. Use the plus or minus buttons to adjust up or down the CFM settings. Once adjustments are completed, press **continue**.
9. Under the **select test to run**, you may un-check any test not required, or run all test. Press **start tests** to proceed. Once each test section is completed, press continue to proceed to the next group of test.
10. Once all test are completed, press done. The will return you to the select tests to run screen. If finish, press the **back** arrow (<) at the top left-hand of the screen to return to the **dealer control center**. Press exit to return the HOME screen.

TIPS

If the HD Display “System Setting” does not offer a choice for “emerg. heat” and or the electric heat will not function; the electric heat has not been configured. Configure the electric heat as described on page 10, or for complete detail, see the air handler installation instructions. Reconfigure the iComfort® system by entering the installer program and selecting the **setup** button and following the prompts.

An outdoor temperature sensor is provided in all iComfort® outdoor. To display the outdoor temperature on the home screen of the HD Display, you can enable this feature under the dealer control center. Use the following procedure to enable the outdoor temperature sensor display.



← HOME screen menu icon

1. Press the **Menu** icon on the Home screen and then **press settings**.
2. Press **advanced settings** and then press **view dealer control center**.

3. Press **equipment** and then press **thermostat**.
4. Press **Outdoor Temperature** and select **sensor**. Press the **back** arrow (<) at the top left-hand of the screen to return to the **dealer control center**.
5. Press **exit**

To enable the Indoor Humidity Display on the Home screen use the following procedure:

1. Press the **Menu** icon on the Home screen and then **press settings**.
2. Press **advanced settings** and then press **view dealer control center**.
3. Press **equipment** and then press **thermostat**.
4. Press **Display Indoor Humidity** and toggle to on. Press the **back** arrow (<) at the top left-hand of the screen to return to the **dealer control center**.
5. Press **exit**

COMPLETE ICOMFORT® SYSTEMS — AIR HANDLER AND HEAT PUMP UNIT

An iComfort® air handler (CBX32MV or CBX40UHV) with an iComfort® heat pump (XP17, XP17N, XP21, XP21N or XP25) unit.

IMPORTANT! Be sure to set up the air handler control for heat strips (if used) prior to powering up the system and thermostat.

1. Configure air handler control (AHC) for auxiliary heat strips if used.
2. **Wiring**—See **Communicating System and optional accessories Wiring** diagrams.
 - 4-conductor thermostat wire between the HD Display, Smart-Hub and air handler (R, i+, i-, C)
 - 4-conductor thermostat wire from the air handler terminal strip to the iComfort® heat pump (R, i+, i-, C)
 - Wiring as required for accessories
3. **DO NOT** cut any option link on air handler control.
4. After the entire system is wired, power up the system; the iComfort® S30 will check the system for installed communication devices.
5. During the **Installer System Setup** (see page 14) you will end that process with the **dealer control center**. From there select **equipment** to modified any system or equipment settings.

6. Select Balance Point Control and press **edit**. Use the down arrow to select **Enabled**. A pop-up warning screen indicating that due to enabling Balance Point Control other related parameter values were automatically changed.
7. Complete *Balance Point Control* by editing the High and Low Balance Points. It is not necessary to change the defaults.
8. From the equipment list, press **air handler**. From this air handler screen you will have access to the various airflow settings. Set the system air volumes according the needs of the home.
9. When all CFM settings are complete, press the **back** arrow (<) at the top left-hand of the screen to return to the **dealer control center**. Press **tests** to access the test section
10. Here you will have the opportunity to adjust blower circulation, heating and cooling circulation air flows. Use the plus or minus buttons to adjust up or down the CFM settings. Once adjustments are completed, press **continue**.
11. Under the **select test to run**, you may un-check any test not required, or run all test. Press **start tests** to proceed. Once each test section is completed, press continue to proceed to the next group of test.
12. Once all test are completed, press done. The will return you to the select tests to run screen. If finish, press the **back** arrow (<) at the top left-hand of the screen to return to the **dealer control center**. Press exit to return the HOME screen.

TIPS

If the HD Display “System Setting” does not offer a choice for **emerg. heat** and or the electric heat will not function; the electric heat has not been configured. Configure the electric heat as described on page 10, or for complete detail, see the Air Handler installation instructions. Reconfigure the iComfort® system by entering the installer program and selecting the **setup** button and following the prompts.

An outdoor temperature sensor is provided in all iComfort® outdoor units. To display the outdoor temperature on the home screen of the HD Display, you can enable this feature under the dealer control center. Use the following procedure to enable the outdoor temperature sensor display.

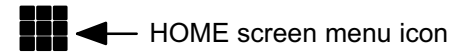

1. Press the **Menu** icon on the Home screen and then **press settings**.
2. Press **advanced settings** and then press **view dealer control center**.
3. Press **equipment** and then press **thermostat**.
4. Press **Outdoor Temperature** and select **sensor**. Press the **back** arrow (<) at the top left-hand of the screen to return to the **dealer control center**.
5. Press **exit**

PARTIAL ICOMFORT® SYSTEM — ICOMFORT® FURNACE AND NON-COMMUNICATING LENNOX BRAND (CONVENTIONAL) AIR CONDITIONER

An iComfort® as furnace (G71MPP, EL296V, SLP98, SL280) with a conventional non-communicating Lennox brand air conditioner.

1. **Wiring**—See **Communicating System and optional accessories Wiring** diagrams.
 - 4-conductor thermostat wire between the HD Display, Smart-Hub and gas furnace (R, i+, i-, C)
 - Conventional thermostat wire with 2 to 4 conductors from the furnace terminal strip to the air conditioner unit (Y1, C, & on some models, R & Y2)
 - Wiring as required for accessories
2. Cut option link **2-stage compr** (Y1 to Y2, W915) on furnace control on two-stage Lennox brand conventional air conditioner units only.
3. After the entire system is wired, power up the system; the iComfort® S30 will check the system for installed communication devices.
4. During the **Installer System Setup** (see page 14) you will arrive at the **equipment found** screen. From there select **non-communicating equipment** to add non-communicating equipment.
5. From the **add/remove equipment** screen, select either **1 Stage A/C unit** or

6. From the equipment list, press **Furnace**. From this furnace screen you will have access to the various airflow settings. Set the system air volumes according to the needs of the home.
7. Continue with the installer setup sequence. When the **set up airflow per zone screen** appears here you can adjust blower, heating and cooling circulation air flows. When done, press **continue** to proceed.
8. The **dealer control center** will appear. Press **tests** to access the test section
9. Here you will have the opportunity to adjust blower circulation, heating and cooling circulation air flows. Use the plus or minus buttons to adjust up or down the CFM settings. Once adjustments are completed, press **continue**.
10. Under the **select test to run**, you may un-check any test not required, or run all test. Press **start tests** to proceed. Once each test section is completed, press **continue** to proceed to the next group of test.
11. Once all test are completed, press **done**. This will return you to the **select tests to run** screen. If finish, press the **back** arrow (<) at the top left-hand of the screen to return to the **dealer control center**. Press **exit** to return to the HOME screen.

TIPS

If the HD Display home screen mode select only lists **heat only** or **off** choices and does not offer a choice for **cooling** or **heat/cool** you must add the non-communicating air conditioning unit. Use the following procedures from the Home screen to add non-communicating air conditioner.

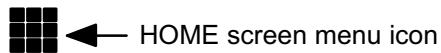

1. Select **Menu > settings > advance settings > view dealer control center > equipment**.
2. Select either **1 Stage A/C** or **2 Stage A/C**. Press the **back** arrow (<) at the top left-hand of the screen to return to the **dealer control center**.
3. Press **exit** to return to the HOME screen.

On two-stage air conditioners you must cut the “W915 2 Stage Compr” link on the furnace control.

Partial iComfort® System — iComfort® Furnace and Non-Communicating Lennox Brand (Conventional) Heat Pump Unit (Dual-Fuel)

If using a conventional non-communicating heat pump unit in an iComfort® dual-fuel system then a iComfort® Equipment Interface Module must be used and set up as a communicating heat pump.

PARTIAL iCOMFORT® SYSTEM — iCOMFORT® AIR HANDLER AND NON-COMMUNICATING LENNOX BRAND (CONVENTIONAL) AIR CONDITIONER

An iComfort® air handler (CBX32MV or CBX40UHV) with a conventional non-communicating Lennox brand air conditioner unit.

IMPORTANT! Be sure to set up the air handler control for heat strips (if used) prior to powering up the system and iComfort® S30 Control System.

1. Configure air handler control (AHC) for auxiliary heat strips if used.
2. **Wiring**—See **Communicating System and optional accessories Wiring** diagrams.
 - 4-conductor thermostat wire from the iComfort® thermostat to the air handler (R, i+, i-, C)
 - iComfort® air handler to conventional Lennox brand air conditioner (5 – 8 wires). (Y1, Y2, C, R, W1,W2)
 - Wiring as required for accessories
3. On air handler control, when matched with conventional Lennox brand 2-stage air conditioner, cut the **Y1-Y2 2 stage comp** on-board clippable link.
4. On air handler control, remove jumper between **W1** and **W2** for two-stage electric heat only.
5. After the entire system is wired, power up the system; the iComfort® S30 will check the system for installed communication devices.
6. During the **Installer System Setup** (see page 14) you will arrive at the **equipment found** screen. From there select **non-communicating equipment** to add non-communicating equipment.
7. From the **add/remove equipment** screen, select either **1 Stage A/C unit** or **2 Stage A/C unit**. Press the **done** to return to the **equipment found** screen. Press **continue** to proceed to the next screen.
8. Continue with the installer setup sequence. When the **set up airflow per zone screen** appears here you can adjust blower, heating and cooling circulation air flows. When done, press **continue** to proceed.
9. The **dealer control center** will appear. Press **tests** to access the test section
10. Here you will have another opportunity to adjust blower circulation, heating and cooling circulation air flows. Use the plus or minus buttons to adjust up or down the CFM settings. Once adjustments are completed, press **continue**.
11. Under the **select test to run**, you may un-check any test not required, or run all test. Press **start tests** to proceed. Once each test section is completed, press continue to proceed to the next group of test.
12. Once all test are completed, press done. The will return you to the select tests to run screen. If finish, press the **back** arrow (<) at the top left-hand of the screen to return to the **dealer control center**. Press exit to return the HOME screen.

TIPS

If the HD Display “System Setting” does not offer a choice for **emerg. heat** and or the electric heat will not function; the electric heat has not been configured. Configure the electric heat as described on page 10, or for complete detail, see the air handler installer program. To start the reconfiguration option:

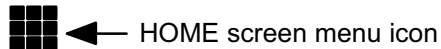

1. From the **Home** screen, press menu and then settings.
2. Press **advanced settings** and press view **dealer control center**.
3. Press **equipment** and press **reset all equipment**. This will restore all settings to the factory default and start the installer setup sequence.

If the HD Display home screen mode select only lists **heat only** or **off** choices and does not offer a choice for **cooling** or **heat/cool** you must add the non-communicating air conditioning unit.

1. Select **Menu > settings > advance settings > view dealer control center > equipment**.
2. Select either **1 Stage A/C** or **2 Stage A/C**. Press the **back** arrow (<) at the top left-hand of the screen to return to the **dealer control center**.
3. Press **exit** to return the HOME screen.

On two-stage air conditioners you must cut the “W915 2 Stage Compr” link on the furnace control.

Partial iComfort® System — iComfort® Furnace and Non-Communicating Lennox Brand (Conventional) Heat Pump Unit (Dual-Fuel)

- If the *HD Display System Setting* only shows “heat only” or “off” choices and does not offer a choice for “cooling” you must “Install” the non-communicating air conditioning unit (see procedures above).
- For two-stage air conditioners you must cut the **Y1-Y2 2 stage comp** on-board clippable link on the air handler control.

PARTIAL ICOMFORT® SYSTEM — ICOMFORT® AIR HANDLER AND NON-COMMUNICATING LENNOX BRAND (CONVENTIONAL) HEAT PUMP UNIT

An iComfort® air handler (CBX32MV or CBX40UHV) with a conventional non-communicating Lennox brand heat pump unit.

IMPORTANT! Be sure to set up the air handler control for heat strips (if used) prior to powering up the system and iComfort® S30.

1. Configure air handler control (AHC) for auxiliary heat strips if used.
2. **Wiring**—See **Communicating System and optional accessories Wiring** diagrams.
 - 4-conductor thermostat wire between the HD Display, Smart-Hub and gas air handler (R, i+, i-, C)
 - Conventional thermostat wire with 5 to 6 conductors from iComfort™ air handler to conventional HP (5 – 8 wires). (Y1, C, R, W1, O, and on some models Y2)
 - Wiring as required for accessories
3. On air handler control:
 - When matched with conventional Lennox brand 2-stage heat pump, cut the **Y1-Y2 2 stage comp** on-board clippable link.
 - Remove jumper between **W1** and **W2** for two-stage electric heat only.
 - Cut on-board **R-O** clippable link.

4. After the entire system is wired, power up the system and the iComfort® S30 will check the system for installed communication devices.
5. During the **Installer System Setup** (see page 14) you will arrive at the **equipment found** screen. From there select **non-communicating equipment** to add non-communicating equipment.
6. From the **add/remove equipment screen** select the *Outdoor Unit Type* from the device list (1-stage HP or 2-stage HP) and press the **done** to return to the **equipment found** screen. Press **continue** to proceed to the next screen
7. Continue with the installer setup sequence until you reach the **dealer control center**. Press **equipment** to continue.
8. Select air handler from the list. From this **air handler** screen you will have access to the various airflow settings. Set the system air volumes according to the needs of the home. When all CFM settings are complete, press the **back** button.
9. Test the system operation and confirm the system is electrically energized and operational. Particularly, test the heat strips (when used) to insure the auxiliary stages operate as designed. Press **done**.
10. Exit the **dealer control center** by selecting the **EXIT** to return to the Home screen.

TIPS

If the HD Display “System Setting” does not offer a choice for **emerg. heat** and or the electric heat will not function; the electric heat has not been configured. Configure the electric heat as described on page 10, or for complete detail, see the air handler installer program. To start the reconfiguration option:

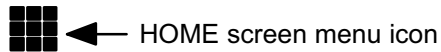

1. From the Home screen, press menu and then settings.
2. Press **advanced settings** and press view **dealer control center**.
3. Press **equipment** and press **reset all equipment**. This will restore all settings to the factory default and start the installer setup sequence.

An outdoor temperature sensor is provided in all iComfort® outdoor units. To display the outdoor temperature on the home screen of the HD Display, you can enable this feature under the dealer control center. Use the following procedure to enable the outdoor temperature sensor display.

1. Press **Menu** and then **press settings**.
2. Press **advanced settings** and then press **view dealer control center**.
3. Press **equipment** and then press **thermostat**.
4. Press **Outdoor Temperature** and select **sensor**. Press the **back** arrow (<) at the top left-hand of the screen to return to the **dealer control center**.
5. Press **exit** to return the HOME screen.

PARTIAL ICOMFORT® SYSTEM — ICOMFORT® EQUIPMENT INTERFACE MODULE

The iComfort® Equipment Interface Module (EIM) can be configured in the following setups:

- iComfort Wi-Fi®, iComfort® Equipment Interface Module with either a non-communicating (conventional) indoor unit and iComfort® outdoor unit.
 - iComfort Wi-Fi®, iComfort® Equipment Interface Module with either a non-communicating (conventional) indoor unit and outdoor unit.
 - iComfort Wi-Fi®, iComfort® furnace, iComfort® Equipment Interface and a non-communicating heat pump
1. **Wiring**—See **Communicating System and Optional Accessories Wiring** diagrams.
 - 4-conductor thermostat wire between the HD Display, Smart-Hub and gas equipment interface module (R, i+, i-, C)
 - 4-conductor thermostat wire from the iComfort® S30 to the heat pump (R, i+, i-, C)
 - Up to 8-conductor thermostat wire from the non-communicating furnace terminal strip to the equipment interface module (R, C, O, Y1, Y2, G, W1, W2 and W3).
 - Wiring as required for accessories
 2. **DO NOT** cut any option link on furnace control.
 3. After the entire system is wired, power up the system; the iComfort® S30 will check the system for installed communication devices.

4. During the **Installer System Setup** (see page 14) you will arrive at the **equipment found** screen. From there select **non-communicating equipment** to add non-communicating equipment.
5. From the **add/remove equipment screen**, select either **1 Stage A/C unit** or **2 Stage A/C unit**. Press the **done** to return to the **equipment found** screen. Press **continue** to proceed to the next screen.
6. Continue with the installer setup sequence. When the **set up airflow per zone screen** appears here you can adjust blower, heating and cooling circulation air flows. When done, press **continue** to proceed.
7. The **dealer control center** will appear. Press **tests** to access the test section
8. Here you will have another opportunity to adjust blower circulation, heating and cooling circulation air flows. Use the plus or minus buttons to adjust up or down the CFM settings. Once adjustments are completed, press **continue**.
9. Under the **select test to run**, you may un-check any test not required, or run all test. Press **start tests** to proceed. Once each test section is completed, press continue to proceed to the next group of test.
10. Once all test are completed, press done. The will return you to the select tests to run screen. If finish, press the **back** arrow (<) at the top left-hand of the screen to return to the **dealer control center**. Press exit to return the HOME screen.

TIPS

An outdoor temperature sensor is provided in all iComfort® outdoor units. To display the outdoor temperature on the home screen of the HD Display, you can enable this feature under the dealer control center. Use the following procedure to enable the outdoor temperature sensor display.

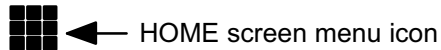

1. Press **Menu** and then **press settings**.
2. Press **advanced settings** and then press **view dealer control center**.
3. Press **equipment** and then press **thermostat**.
4. Press **Outdoor Temperature** and select **sensor**. Press the **back** arrow (<) at the top left-hand of the screen to return to the **dealer control center**.
5. Press **exit** to return the HOME screen.

6. Press the Home icon at the top left-hand corner of the screen to return to Home screen.

To enable the Indoor Humidity Display on the Home screen use the following procedure:

1. Press **Menu** and then **press settings**.
2. Press **advanced settings** and then press **view dealer control center**.
3. Press **equipment** and then press **thermostat**.
4. Press **Display Indoor Humidity** and toggle to on. Press the **back** arrow (<) at the top left-hand of the screen to return to the **dealer control center**.
5. Press **exit** to return the HOME screen.

Turn the Indoor humidity display on and off in a similar manner as above.

PARTIAL ICOMFORT® SYSTEM — ICOMFORT® FURNACE AND NON-COMMUNICATING LENNOX BRAND (CONVENTIONAL) HEAT PUMP UNIT (DUAL-FUEL)

- If the *HD Display System Setting* only shows “heat only” or “off” choices and does not offer a choice for “cooling” you must “Install” the non-communicating air conditioning unit (see procedures above).
- For two-stage air conditioners you must cut the **Y1-Y2 2 stage comp** on-board clippable link on the air handler control.

G71MPP OR SLP98 FURNACE SETTING ADJUSTMENT

If your iComfort® S30 is being used with either a G71MPP or SLP98 furnace and is set to variable-capacity mode of operation (the iComfort® default with these units), the system's settings for stage timers are ignored (even if shown enabled in the S30 Control System). The stage timer will be used on the cooling side for other cooling units except the XC20, SL18XC1/XP1 and XC/XP25 where they are not used. The furnace software sets and controls the firing rates. The only other controlling factor is the stage temperature differentials. In Load-Tracking Variable Capacity (default for these furnaces), both stage timers and temperature differentials are ignored.

GLOSSARY

AC - air conditioner

AHC - Air Handler Control

CEHB - Cold end header box

CFA - Comfort fault alarm

CFM - Short for cubic feet per minute, a measurement of the velocity at which air flows into or out of a space.

DAS - Discharge air sensor

DAT - Discharge air temperature

DC - Direct current

DCM - Damper control module

Deadband - Is an interval of a signal domain or band where no action occurs (the system is dead).

Dual-Fuel - Refers to a system having the option of two **fuel** sources to maximize efficiency. **Dual-fuel** systems optimize energy use by selecting the best source of **fuel**, like Lennox systems that combine an electric heat pump with a high-efficiency gas or oil furnace.

EIM - Equipment Interface module

HEPA - is an acronym for "**High Efficiency Particulate Air**" or "High Efficiency Particulate Arrestance." This acronym refers to a filter that is manufactured, tested, certified, and labeled in accordance with current **HEPA** filter standards.

HP - Heat pump

IFC - Integrated Furnace Control

LED - A **light-emitting diode (LED)** is a two-lead semiconductor light source. It is a pn-junction diode, which emits light when activated. When a suitable voltage is applied to the leads, electrons are able to recombine with electron holes within the device, releasing energy in the form of photons.

LVCS - Lennox Ventilation Control System

Mag-Mount - A wall base that has inter-connects between the wall display and the Smart Hub.

MAX - Maximum

Modulating - The process of varying one or more properties of a high-frequency periodic waveform.

OAS - Outdoor air sensor

PCB - Printed circuit board

PFC - In electrical engineering, the **power factor** of an AC electrical power system is defined as the ratio of the real power flowing to the load, to the apparent power in the circuit,[1][2] and is a dimensionless number in the closed interval of -1 to 1.

PureAir - A system uses exclusive UVA-light technology to attack all three classes of indoor air contaminants—particles, mold/mildew/bacteria and odors/chemical vapors. It not only reduces, but also destroys ozone, a known lung irritant.

RPM - Number of times the shaft of a motor, rotates in one minute. RPM is a function of the design of the equipment and the power supply.

RSBus - Residential Serial Bus * the means for transmitting data within the communicating system.

Set point - It is the temperature the control system aims to maintain.

Smart Hub - System and network controller

SSA - Single set point

SSID - Is a case sensitive, 32 alphanumeric character unique identifier attached to the header of packets sent over a wireless local-area network (WLAN) that acts as a password when a mobile device tries to connect to the basic service set (BSS) -- a component of the IEEE 802.11 WLAN architecture.

TEMP - Temperature

TXV - The thermostatic expansion valve (**TXV**) is a precision device, which is designed to regulate the rate at which liquid refrigerant flows into the evaporator.

VAC - Variable alternate current

VDC - Variable direct current

UV - Ultra-violet

UVC - Refers to ultraviolet light with wavelengths between 200 – 280 nanometers (nm). Light in the **UVC** wavelength can be used for disinfecting water, sterilizing surfaces, destroying harmful micro-organisms in food products and in air.

Wi-Fi - A facility allowing computers, smartphones, or other devices to connect to the Internet or communicate with one another wirelessly within a particular area.

FCC COMPLIANCE STATEMENT — PART 15.19

This device complies with Part 15 of the FCC Rules.

Operation is subject to the following two conditions:

1. This device may not cause harmful interference, and
2. This device must accept any interference received, including interference that may cause undesired operation.

FCC INTERFERENCE STATEMENT — PART 15.105 (B)

This equipment has been tested and found to comply with the limits for a Class B digital device, pursuant to Part 15 of the FCC Rules. These limits are designed to provide reasonable protection against harmful interference in a residential installation. This equipment generates uses and can radiate radio frequency energy and, if not installed and used in accordance with the instructions, may cause harmful interference to radio communications. However, there is no guarantee that interference will not occur in a particular installation. If this equipment does cause harmful interference to radio or television reception, which can be determined by turning the equipment off and on, the user is encouraged to try to correct the interference by one of the following measures:

- Reorient or relocate the receiving antenna.
- Increase the separation between the equipment and receiver.
- Connect the equipment into an outlet on a circuit different from that to which the receiver is connected.
- Consult the dealer or an experienced radio/TV technician for help.

RF EXPOSURE INFORMATION

This equipment complies with FCC radiation exposure limits set forth for an uncontrolled environment. In order to avoid the possibility of exceeding the FCC radio frequency exposure limits, human proximity to the antenna shall not be less than 20cm during normal operation.

REPLACEMENT PARTS

The following iComfort® S30 component parts can be ordered:

Catalog Number	Component	Remarks
12X97	HD Display	Thermostat interface
12X98	Smart Hub	Control base
12X99	Mag-Mount	Wall mount for HD Display
13X01	Wall plate	Wall plate for Mag-Mount (use is optional)
12X97V	HD Display Software for non-thermostat devices	HD Display interface software running on PC using Blues-tacks or non-thermostat Android tablet running Android 4.3.
12X98V	Smart Hub virtual software	Smart Hub Windows 7 based emulator.

APPENDIX A - INDEX

A

Add / Remove Equipment, 27
Advanced Settings, 22
Air Conditioner, 24
 About, 24
 Compressor Short Cycle Delay, 24
 Dehum Airflow Adjustment Adder, 23, 24
 Equipment Name, 24
 High Normal Cooling Airflow, 24
 Low Normal Cooling Airflow, 24
 Reset, 24
Air Handler, 24
 About, 24
 Airflow Profile - Cooling, 25
 Continuous Indoor Blower Airflow, 25
 Cooling Indoor Blower Off Delay, 25
 Cooling Indoor Blower On Delay, 25
 Equipment Name, 24
 Heating Indoor Blower Delay, 25
 Heating Indoor Blower Off Delay, 25
 High Cooling Airflow, 24
 High HP Airflow, 25
 HP Indoor Blower Off Delay, 25
 HP Indoor Blower On Delay, 25
 Reset Air Handler, 25
Airflow Profile - Cooling, 25
Alert Codes and Troubleshooting, 28
Auto Brightness, 26
Auto Changeover - Humidif Deadband, 20
Auto Changeover - Temp Deadband, 19
Aux Heating Activation Threshold, 19

B

Balance Point Control, 20
Best Practices, 9
Bootup Screen, 14

Brightness Value, 26

C

Compressor Shift Delay ON/OFF, 22
Compressor Short Cycle Delay, 22, 24
Continuous Indoor Blower Airflow, 25
Cooling Indoor Blower Off Delay, 25
Cooling Indoor Blower On Delay, 25
Cooling Mode, 19

D

Dealer Application Connection, 13
Dealer Control Center, 16
Dealer Information, 49
Defrost Termination Temp, 22
Dehum Airflow Adjustment Adder, 23, 24
Dew Point Adjustment, 20
Diagnostics, 49
Discharge Air Sensor (DAS), 5
Display Indoor Humidity, 26
Display Outdoor Weather, 26

E

Electric Heat Configuration, 10
Electric Heat Control, 17
Electric heat Stages During Defrost, 20
Electric Heating Airflow, 24
Equipment, 17
Equipment Found, 14
Equipment Name, 17, 22, 24, 25, 27
Evenheat Discharge Temp, 17

F

Freezing Alert Temperature, 21
Furnace, 25
 About, 25
 Continuous Indoor Blower Airflow, 25
 Equipment Name, 25

Heating Airflow Control Type, 26
Heating Indoor Blower Off Delay, 25
Heating Indoor Blower On Delay, 26
High Heating Airflow, 26
Low Heating Airflow, 26
Reset Furnace, 26

G

Gas Heat Control Mode, 17
Gas Heating Activation Temp Difference, 17
General, 2
General Information, 49
 Country / Region, 14
 Language, 14
 Temperature Unit, 14

H

HD Display, 26
HD Display Installation, 4
Heat Alert Temperature, 21
Heat Cool Stages Locked In, 19
Heat Pump, 22
 About, 22
 Compressor Shift Delay ON/OFF, 22
 Compressor Short Cycle Delay, 22
 Defrost Termination Temp, 22
 Equipment Name, 22
 High Normal Cooling Airflow, 23
 High Normal HP Heating Airflow, 23
 Low Normal Cooling Airflow, 23
 Low Normal HP Heating Airflow, 23
 Max Defrost, 23
 Reset Heat Pump, 23
Heating Airflow Control Type, 26
Heating Indoor Blower Delay, 25
Heating Indoor Blower Off Delay, 25
Heating Indoor Blower On Delay, 26
High Balance Point, 20
High Cooling Airflow, 24

High Heating Airflow, 26
High HP Airflow, 25
High Normal Cooling Airflow, 23, 24
High Normal HP Heating Airflow, 23
Home Address, 14, 49
HP Heating Lockout Temp, 21
HP Heating Mode, 21
HP Indoor Blower Off Delay, 25
HP Indoor Blower On Delay, 25
Humiditrol Comfort Adjust, 20

I

Information, 49
 Dealer Information, 49
 General Information, 49
 Home Address, 49
Installer System Setup, 14

L

Lock In 2nd Stage HP By Outdoor Temp, 20
Low Balance Point, 20
Low Heating Airflow, 26
Low Normal Cooling Airflow, 23, 24
Low Normal HP Heating Airflow, 23

M

Mag-Mount Installation, 3
Maintenance History, 49
Tests, 49
Max Defrost, 23
Max Heat Setpoint, 19
Max Humidification Setpoint, 20
Min Cool Setpoint, 19
Min Dehumidification Setpoint, 20
Mobile Application, 13
Modulating HP Heating Steady State PI Gain, 18
Modulating Cooling Steady Change PI Gain, 19
Modulating Cooling Cycles Per Hour, 19

Modulating Cooling Steady State PI Gain, 19
Modulating Gas Heating Cycles Per Hour, 18
Modulating Gas Heating Steady State PI Gain, 18
Modulating Gas Heating Step Change PI Gain, 18
Modulating HP Heating Cycles Per Hour, 18
Modulating Step Change, Understanding, 18

N

Non-Communicating Equipment, 15
Notifications, 28
Number of Gase Heating Stages, 18

O

Outdoor Air Sensor (OAS), 5
Outdoor Temperature, 26
Outdoor Temperature Reading Calibration, 21

P

Proximity Control, 26
PureAir Timer Selection, 17

R

Reminders, 15
Replacement Parts, 60
Reset All Equipment, 27

S

Screen Locked, 26
Screen Saver, 26
Severe Weather Protection, 21
Single Setpoint Mode, 19
Smart Hub, 17
 Controller Installation, 4
Smart Hub Center Button Functions, 11
Smart Hub Controller Installation, 4
Smart Hub Indicators and Connectors, 12
Smart Hub LED Indicators, 12

Smart Hub Operations, 11
Smart Hub Wi-Fi, 11
Smooth Setback Recovery, 17
SSP Cooling Cancel Cast Counter Decrement Slope, 19
SSP Cooling Cancel Cast Counter Increment Slope, 19
SSP Cooling Lockout Outdoor Temp, 19
SSP Cooling Cancel Cast Heating Decrement Slope, 19
SSP Heating Cancel Cast Counter Increment Slope, 19
SSP Heating Lockout Outdoor Temp, 19
Stage Delay Timers, 20
Stage Delays, 20
Stage Differentials, 19
Steady State PI Gains, Understanding, 18
System
 About, 17
 Advanced Settings, 22
 Auto Changeover - Humidif Deadband, 20
 Auto Changeover - Temp Deadband, 19
 Aux Heating Activation Threshold, 19
 Balance Point Control, 20
 Cooling Mode, 19
 Dew Point Adjustment, 20
 Electric Heat Control, 17
 Electric heat Stages During Defrost, 20
 Evenheat Discharge Temp, 17
 Freezing Alert Temperature, 21
 Gas Heat Control Mode, 17
 Gas Heating Activation Temp Difference, 17
 Heat Alert Temperature, 21
 Heat Cool Stages Locked In, 19
 High Balance Point, 20
 HP Heating Lockout Temp, 21
 HP Heating Mode, 21
 Humiditrol Comfort Adjust, 20
 Lock In 2nd Stage HP By Outdoor Temp, 20
 Low Balance Point, 20
 Max Heat Setpoint, 19
 Max Humidification Setpoint, 20
 Min Cool Setpoint, 19
 Min Dehumidification Setpoint, 20
 Modulating Cooling Change State PI Gain, 19

- Modulating Cooling Cycles Per Hour, 19*
- Modulating Cooling Steady State PI Gain, 19*
- Modulating Gas Heating Cycles Per Hour, 18*
- Modulating Gas Heating Steady State PI Gain, 18*
- Modulating Gas Heating Step Change PI Gain, 18*
- Modulating HP Heating Cycles Per Hour, 18*
- Modulating HP Heating Steady State PI Gain, 18*
- Modulating HP Heating Step Change PI Gain, 18*
- Equipment, 17*
- Number of Gase Heating Stages, 18*
- Outdoor Temperature Reading Calibration, 21*
- PureAir Timer Selection, 17*
- Severe Weather Protection, 21*
- Single Setpoint Mode, 19*
- Smooth Setback Recovery, 17*
- SSP Cooling Cancel Cast Counter Decrement Slope, 19*
- SSP Cooling Cancel Cast Counter Increment Slope, 19*
- SSP Cooling Lockout Outdoor Temp, 19*
- SSP Heating Cancel Cast Counter Decrement Slope, 19*
- SSP Heating Cancel Cast Counter Increment Slope, 19*
- SSP Heating Lockout Outdoor Temp, 19*
- Stage Delay Timers, 20*
- Stage Delays, 20*
- Stage Differentials, 19*
- Temperature Control Mode, 19*
- Zone 1 thru 4 Continuous Blower CFM, 22*
- Zone 1 thru 4 Cooling CFM, 22*
- Zone 1 thru 4 First Stage Differential, 22*
- Zone 1 thru 4 Heating CFM, 22*
- Zoning Anticipated Discharge Air Temperature Adjustment, 21*
- Zoning Gas heating DAT Cooldown Target, 21*
- Zoning Minimum Zone Run Time, 21*
- Zoning Supply Air Temp Limit for Cooling, 21*
- Zoning Supply Air Temp Limit for Gas/Electric Heating, 21*
- Zoning Target Supply Air Temp for Cooling, 21*
- Zoning Target Supply Air Temp for Heating, 21*
- System Configurations, 50, 59*

T

- Thermostat, 26
 - About, 26*
 - Auto Brightness, 26*
 - Brightness Value, 26*
 - Display Indoor Humidity, 26*
 - Display Outdoor Weather, 26*
 - Outdoor Temperature, 26*
 - Proximity Control, 26*
 - Reset Thermostat, 26*
 - Screen Saver, 26*
- Thermostat Wiring, 5

W

- Wireless Bands, 2
- Wiring Diagrams, 5

Z

- Zone 1 thru 4 Continuous Blower CFM, 22
- Zone 1 thru 4 Cooling CFM, 22
- Zone 1 thru 4 First Stage Differential, 22
- Zone 1 thru 4 Heating CFM, 22
- Zones 1 thru 4 Temp Reding Calibration, 27
- Zoning Anticipated Discharge Air Temperature Adjustment, 21
- Zoning Control, 27
 - About, 27*
 - Equipment Name, 27*
 - Reset Zoning Control, 27*
 - Zones 1 thru 4 Temp Reding Calibration, 27*
- Zoning Gas Heating DAT Cooldown Target, 21
- Zoning Minimum Zone Run Time, 21
- Zoning Supply Air Temp Limit for Cooling, 21
- Zoning Supply Air Temp Limit for Gas/Electric Heating, 21
- Zoning Target Supply Air Temp for Cooling, 21
- Zoning Target Supply Air Temp for Heating, 21